



Installation Manual

# ***PosiStrobe MiniMax***

Position / Strobe LED Light

**AveoEngineering**<sup>™</sup>

© Aveo Engineering Group, s.r.o.  
[www.aveoengineering.com](http://www.aveoengineering.com)

**Table of Contents**

1. *PosiStrobe MiniMax* ..... 3  
*Main Features:* ..... 3  
2. *WIRING DIAGRAM* ..... 4  
3. *CONTROL & POWER INPUTs:* ..... 4  
4. *TECHNICAL SPECIFICATION* ..... 5  
5. *TECHNICAL DRAWING* ..... 6  
6. *WIRING CHART* ..... 7  
7. *TESTING THE FUNCTION OF THE AVEO AURORA SERIES LIGHTS BEFORE  
INSTALLATION* ..... 8  
8. *CARE AND CLEANING OF YOUR AVEO ENGINEERING AVIATION LIGHTS* ..... 9

## 1. PosiStrobe MiniMax

Developed originally at the request of the world's leading UAV manufacturers, all of which now utilize Aveo lighting, the MiniMax is a compact powerhouse of hemispheric light. Available in red or white LEDs, it is an ideal anticollision light for very light aircraft or UAVs. It is also a great anticollision light to use on upper and lower fuselage in combination with AveoFlash wing lights due to its incredibly small footprint.

Encapsulated in the exclusive AveoDiamidium™ formulation, the Minimax lights are virtually unbreakable and with our exclusive aircraft lifetime warranty there is no risk to the owner that he will ever need to buy another set of wing lights again. Our policy is simple, **IF IT FAILS WE REPLACE IT!**

### Main Features:

- 2-in-1 Position & Strobe, popular miniature anticollision light for Trikes, PPC, UAVs, ultralights
- extremely lightweight at only 53 grams
- 9-32 volt DC input range
- no external power supply or strobe unit
- light synchronization feature
- minimum drag profile
- unbreakable Diamidium™ encapsulation
- exclusive Lifetime Warranty
- unmatched circuit technology
- advanced computer and goniophotometer engineered optics

## 2. WIRING DIAGRAM

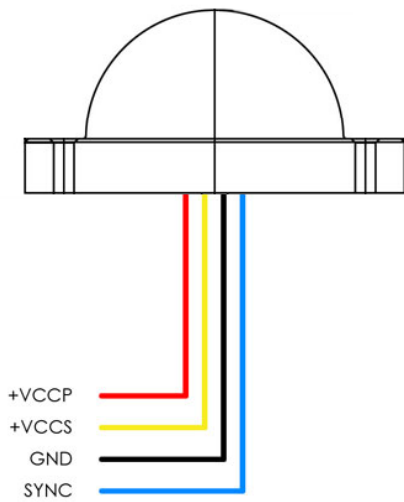

## 3. CONTROL & POWER INPUTS:

- |              |   |
|--------------|---|
| <b>+VCCP</b> | - positive position power supply line   |
| <b>+VCCS</b> | - positive strobe power supply line   |
| <b>GND</b>   | - negative common power supply line (ground)  |
| <b>SYNC</b>  | - strobe synchronization line (mutually interconnect on all installed AveoFlash lights) |

**4. TECHNICAL SPECIFICATION**

Dimensions:	<i>56 mm x 44.5 mm x 26 mm 2.2" x 1.75" x 1.02"</i>
Weight:	<i>53 g / 1.87 oz</i>
Operating Voltage Range:	<i>9 – 32 Vdc</i>
Power – position:	<i>2.6 W</i>
Power – strobe:	<i>5.5 W (27.6 W peak)</i>
Current – position (@12V):	<i>0.22 A</i>
Current – strobe (@12V):	<i>0.46 A (2.7 A peak)</i>
Repetition Flash Rate of Strobe:	<i>50 cycles per minute</i>
Recommended size of mounting screw:	<i>M3, stainless steel recommended. Length depends upon placement location on wing tips.</i>

5. TECHNICAL DRAWING

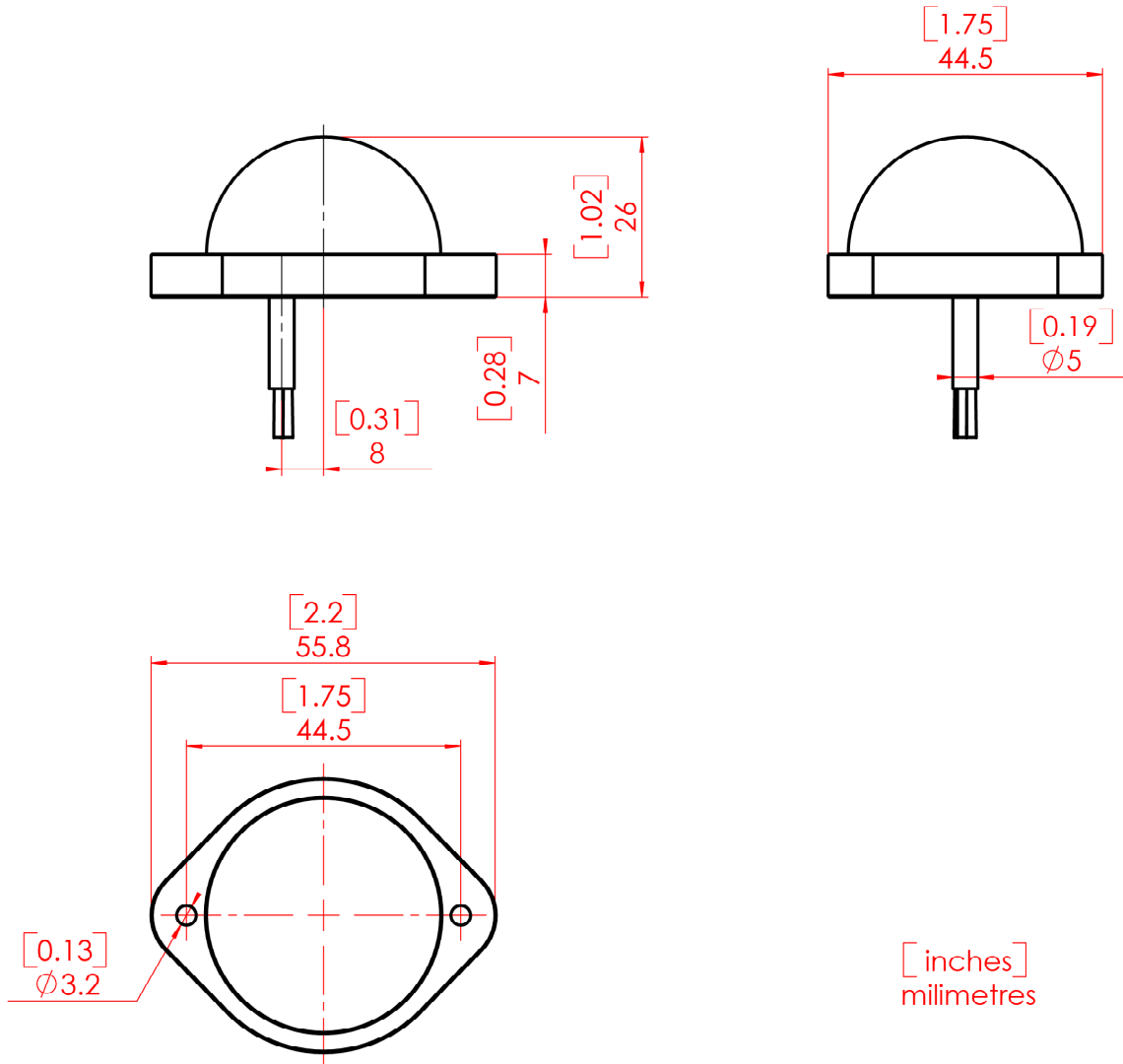

## 6. WIRING CHART

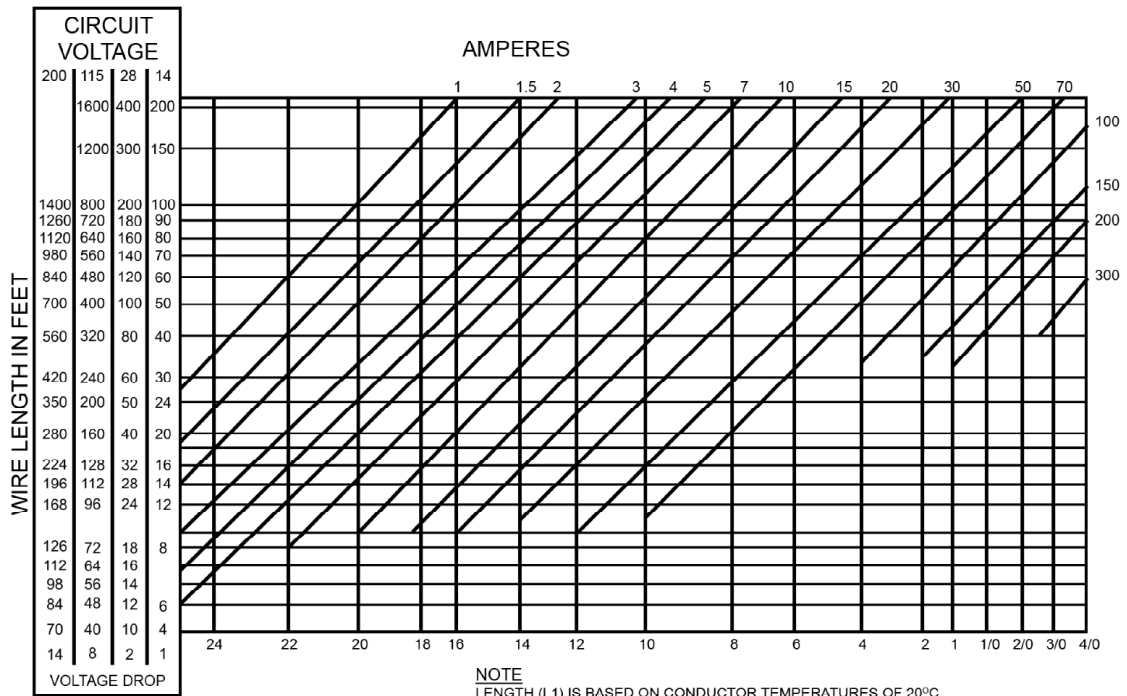

**NOTE**  
 LENGTH (L1) IS BASED ON CONDUCTOR TEMPERATURES OF 20°C  
 TO DETERMINE LENGTH (L2) AT HIGHER CONDUCTOR TEMPERATURE USE FORMULA  
 WHERE T2 - ESTIMATED CONDUCTOR TEMPERATURE °C

WIRE SIZE  
 VOLTAGE DROP CHART  
 INTERMITTENT FLOW AT 20°  
 TIN-PLATED MIL-W-27759  
 CONDUCTOR

---

## 7. TESTING THE FUNCTION OF THE AVEO AURORA SERIES LIGHTS BEFORE INSTALLATION

All Aveo Aviation lights undergo rigorous testing prior to being released from our engineering manufacturing department. This testing involves a burn-in time as well as other function testing. No light is released for sale without undergoing this extensive operational testing.

When you receive the Aveo Aurora Series Aviation Lights, and wish to test the function of the lights prior to installation on your aircraft, please note the following:

1. Please review the written information that is enclosed in the packaging. Warranty information as well as a cautionary note about power supply removal is enclosed with each package.
2. Remove the lights from the package. Note that there are four (4) wires coming from each light. These wires are:
  - a. Black wire – Ground wire (negative lead)
  - b. Red wire – Position light function wire (positive leads)
  - c. Yellow wire – Strobe light function wire (positive leads)
  - d. Blue wire – used if the synchronization of the Aveo lights is selected
3. Testing of the function of each light can be done with a regular 12V/5A dc power supply (not a battery chargers). Connect the black wire to the ground (negative) leads of a power supply, then connect the red wire to the positive (+) leads on the power supply. The position light should light up. While the red wire is still in contact with the positive side of the power supply, connect the yellow wire to the positive lead. Both the position and the strobe function should work. **Strobe function is separate from the position function and can be tested separately.** To test the strobe function separately, just connect the yellow wire only to the positive terminal of the power supply while the black wire is connected the ground side of the power supply. Connecting the blue wires from each light together (and not to the ground or positive terminals on the battery) should show that the lights are flashing together and indicates the synchronization feature is working properly. When installed on the aircraft, using the aircraft's power (14 or 28 volts), the lights will be at their maximum intensity.

After testing, the lights can be installed on the aircraft.

### IMPORTANT NOTES:

1. Under no circumstances should any power supply other than a 9-32V dc, or a 12/24 volt battery be used to test the lights. Do not use: Battery chargers, battery back-up power devices, or other bench avionics testing methods to test the aviation lights. The lights are functional between 9 and 32 volts. Use of a battery charger or other power unit to test the lights will void the warranty and may damage the lights.
2. All power supplies for existing strobe lights, flasher beacons, etc. are required to be removed from the aircraft prior to the installation of the Aveo lights.

If you have any questions about the installation of the lights, please refer to our web site: [www.aveoengineering.com](http://www.aveoengineering.com), and check FAQ and other links on our aviation lights web page.

## **8. CARE AND CLEANING OF YOUR AVEO ENGINEERING AVIATION LIGHTS**

When you receive your Aveo Engineering Aviation Lights, they will have been factory polished and ready to install on the aircraft. Upon installation, just give the lights a good coat or two of a quality automotive polish. This should protect the lights from dirt and other environmental factors. Once or twice a month, just refresh the polish and hand buff to bring back the lights to factory like new condition.

If the lights need a deeper cleaning, they can be polished with a good automotive cleaner wax and/or a liquid polishing compound. The liquid polishing compounds can normally be found at automotive parts stores or an automotive paint store. After using a polishing compound, just give the lights another coat of an automotive polish and you will again protect the lights against dirt, etc.. An electric buffing machine, with a lamb's wool cover, can also be used for deeper cleaning and polishing. Under no circumstances should any petroleum based product be used to clean the lights.