



Installation Manual

RedBaron XP

Anticollision LED Light RED

AveoEngineering™

© Aveo Engineering Group, s.r.o.
www.aveoengineering.com

Table of Contents

1. *RedBaron XP* 3
Main Features:..... 3

2. *WIRING DIAGRAM*..... 4

3. *CONTROL & POWER INPUTs:*..... 4

4. *TECHNICAL SPECIFICATION*..... 5

5. *TECHNICAL DRAWING*..... 6

6. *WIRING CHART* 7

7. *TESTING THE FUNCTION OF THE AVEO GALACTICA REDBARON XP
ANTICOLLISION LIGHT BEFORE INSTALLATION* 8

8. *CARE AND CLEANING OF YOUR AVEO ENGINEERING AVIATION LIGHTS*..... 9

1. RedBaron XP

The RedBaron series of anticollision lights were designed for certified aircraft requirements. They represent the cutting edge in optics design and the use of LED arrays that have been optimized for coverage patterns. The exclusive Aveo RockyReflectors™ are what separates these lights from any in the industry, and they have been molded after exhaustive modeling and testing in our parent company's world class LED-array measurement lab. (www.strojkovengineering.com) The RedBaron XP™ version incorporates 40 of the brightest LEDs available in the world today, with chromacity and intensity compliant to all international aviation and safety standards. The optical performance is incredible, and these are the ideal replacement unit for any anticollision light system in existence. Come visit us and get a tour of our LED array testing and optimization lab, as there is no such facilities available at ANY of our competition.

The RedBaron XP™ light feature an exclusive Aveo internal reflection system to achieve the appropriate arcs of intensities, and these lights exceed the requirements by a wide margin. Be Seen, Not Sorry is our mantra, and with the RedBaron XP™ light your aircraft will be seen farther away than any other lighting system on the market, and all with the exclusive Aveo patented electronic circuitry.

Encapsulated in the exclusive AveoDiamidium™ formulation, the RedBaron XP™ light is virtually unbreakable and with our exclusive aircraft lifetime warranty there is no risk to the owner that he will ever need to buy another anticollision light again. Our policy is simple, **IF IT FAILS WE REPLACE IT!**

Main Features:

- popular miniature anticollision light for certified aircraft requirements
- extremely lightweight
- 9-32 volt DC input range
- no external power supply or strobe unit
- light synchronization feature
- minimum drag profile
- unbreakable Diamidium™ encapsulation
- exclusive Lifetime Warranty
- unmatched circuit technology
- advanced computer and goniophotometer engineered optics

2. WIRING DIAGRAM

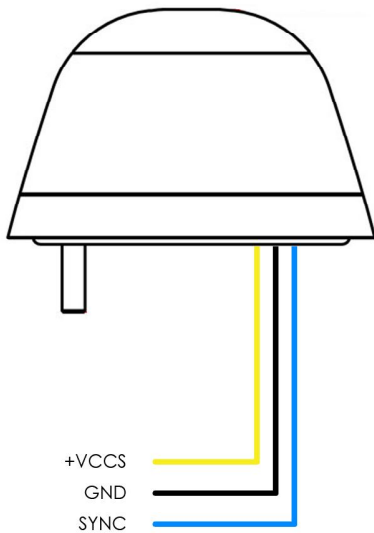

3. CONTROL & POWER INPUTs:

- | | |
|--------------|-----------------------------------------------------------------------------------------|
| +VCCS | - positive strobe power supply line |
| GND | - negative common power supply line (ground) |
| SYNC | - strobe synchronization line (mutually interconnect on all installed AveoFlash lights) |

4. TECHNICAL SPECIFICATION

Dimensions:	<i>64 mm x 64 mm x 40 mm</i> <i>2.52" x 2.52" x 1.57"</i>
Weight:	<i>150 g / 5.29 oz</i>
Operating Voltage Range:	<i>9 – 32 Vdc</i>
Power – strobe:	<i>8.8 W (44 W peak)</i>
Current – strobe (@12V):	<i>0.75 A (3.7 A peak)</i>
Repetition Flash Rate of Strobe:	<i>50 cycles per minute</i>
Exceed requirements of:	<i>- TSO C96a</i> <i>- SAE AS8017a</i> <i>- DO-160F</i>
Recommended size of mounting screw:	<i>5Mx45mm (DIN912) or equivalent</i>

5. TECHNICAL DRAWING

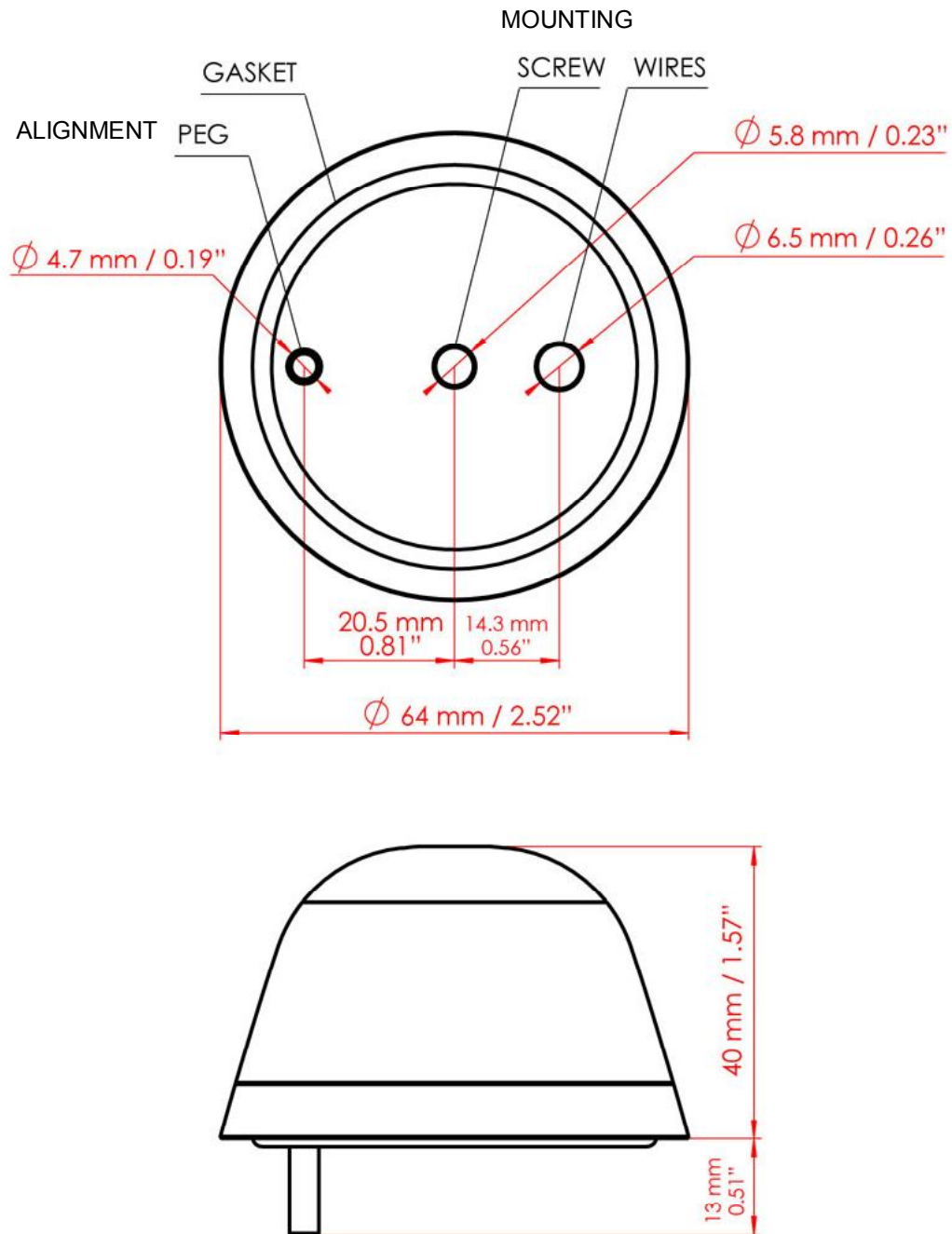

6. WIRING CHART

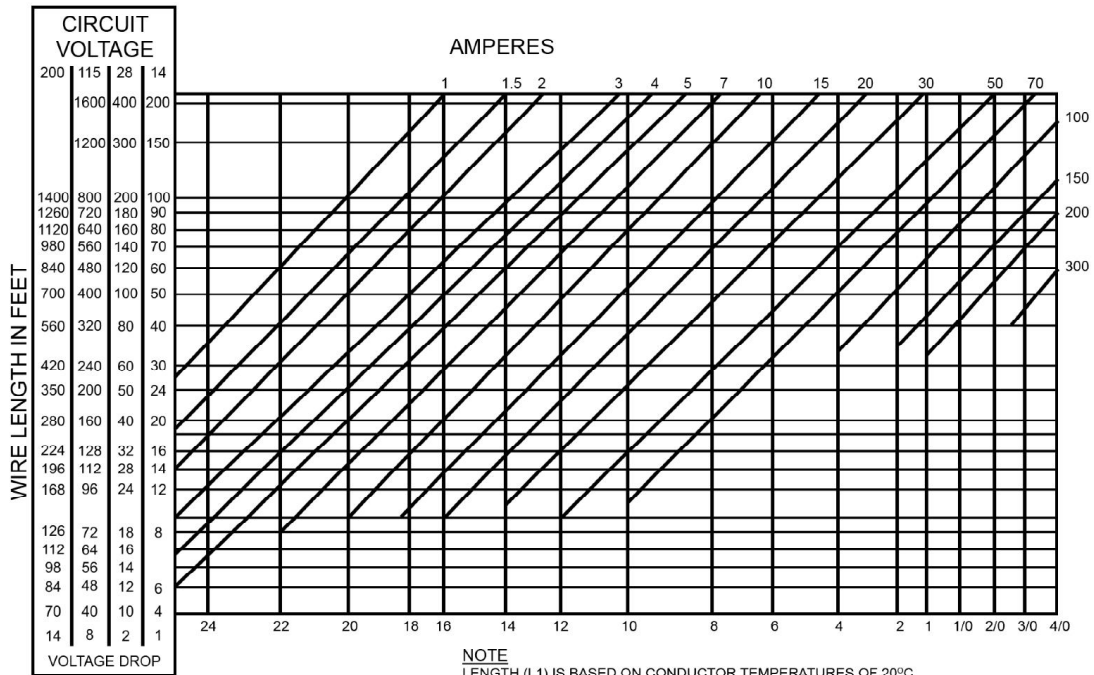

NOTE
 LENGTH (L1) IS BASED ON CONDUCTOR TEMPERATURES OF 20°C
 TO DETERMINE LENGTH (L2) AT HIGHER CONDUCTOR TEMPERATURE USE FORMULA
 WHERE T2 - ESTIMATED CONDUCTOR TEMPERATURE °C

WIRE SIZE
 VOLTAGE DROP CHART
 INTERMITTENT FLOW AT 20°
 TIN-PLATED MIL-W-27759
 CONDUCTOR

7. TESTING THE FUNCTION OF THE AVEO GALACTICA REDBARON XP ANTICOLLISION LIGHT BEFORE INSTALLATION

All Aveo Aviation lights undergo rigorous testing prior to being released from our engineering manufacturing department. This testing involves a burn-in time as well as other function testing. No light is released for sale without undergoing this extensive operational testing.

When you receive the Aveo Galactica RedBaron light, and wish to test the function of the light prior to installation on your aircraft, please note the following:

1. Please review the written information that is enclosed in the packaging. Warranty information as well as a cautionary note about power supply removal is enclosed with each package.
2. Remove the light from the package. Note that there are three (3) wires coming from each light. These wires are:
 - a. Black wire – Ground wire (negative lead)
 - b. Yellow wire – Anticollision light function wire (positive lead)
 - c. Blue wire – used if the synchronization of the Aveo lights is selected
3. Testing of the function of the light can be done with a regular 12V/5A dc power supply (not a battery chargers). Connect the black wire to the ground (negative) leads of a power supply, then connect the yellow wire to the positive (+) leads on the power supply. The anticollision light should start flashing. Connecting the blue wires from each AveoFlash light together (and not to the ground or positive terminals on the battery) should show that the lights are flashing together and indicates the synchronization feature is working properly. When installed on the aircraft, using the aircraft's power (14 or 28 volts), the light will be at its maximum intensity.

After testing, the light can be installed on the aircraft.

IMPORTANT NOTES:

1. Under no circumstances should any power supply other than a 9-32 Vdc, or a 12/24 volt battery be used to test the light. Do not use: Battery chargers, battery back-up power devices, or other bench avionics testing methods to test the aviation light. The light is functional between 9 and 32 volts. Use of a battery charger or other power unit to test the light will void the warranty and may damage the light.
2. All power supplies for existing strobe lights, flasher beacons, etc. are required to be removed from the aircraft prior to the installation of the Aveo light.

If you have any questions about the installation of the lights, please refer to our web site: www.aveoengineering.com, and check FAQ and other links on our aviation lights web page.

8. CARE AND CLEANING OF YOUR AVEO ENGINEERING AVIATION LIGHTS

When you receive your Aveo Engineering Aviation Lights, they will have been factory polished and ready to install on the aircraft. Upon installation, just give the lights a good coat or two of a quality automotive polish. This should protect the lights from dirt and other environmental factors. Once or twice a month, just refresh the polish and hand buff to bring back the lights to factory like new condition.

If the lights need a deeper cleaning, they can be polished with a good automotive cleaner wax and/or a liquid polishing compound. The liquid polishing compounds can normally be found at automotive parts stores or an automotive paint store. After using a polishing compound, just give the lights another coat of an automotive polish and you will again protect the lights against dirt, etc.. An electric buffing machine, with a lamb's wool cover, can also be used for deeper cleaning and polishing. Under no circumstances should any petroleum based product be used to clean the lights.