



INSTALLATION MANUAL

NEBULON™

DOC.NO: AVE-WP-51G-IM

© 2015 Aveo Engineering Group, s.r.o. All rights reserved. The information contained within this document must not be disclosed, copied or reproduced in whole or in part without prior written permission from Aveo Engineering Group, s.r.o. Distribution of this document shall only be as stated in Table 02 unless otherwise agreed by Aveo Engineering Group, s.r.o.

Part 0 Manual Administration

0.1 Table of Contents

PART 0	MANUAL ADMINISTRATION	2
0.1	TABLE OF CONTENTS	2
0.2	DOCUMENT APPROVAL	3
0.3	AMENDMENT RECORD PROCEDURE	3
0.4	EFFECTED PAGES PROCEDURE	4
0.5	DISTRIBUTION LIST	4
1.	NEBULON™	5
2.	OPERATING INSTRUCTIONS	5
3.	INSTALLATION SCHEMATIC / WIRING DIAGRAM	6
4.	CONTROL & POWER INPUT'S:	6
5.	TECHNICAL SPECIFICATION	6
6.	TECHNICAL DRAWING	7
7.	WIRING CHART	7
8.	EQUIPMENT LIMITATION	8
9.	TESTING OF THE LIGHT BEFORE INSTALLATION	8
10.	CARE AND CLEANING OF YOUR AVEO ENGINEERING AVIATION LIGHTS	9
11.	NOTES ON INSTALLATION	9
12.	CONTINUED AIRWORTHINESS INFORMATION	9

0.2 Document approval

This document has been established in accordance with an alternative procedure to DOA approved under EASA AP429.

This installation manual is according EASA ETSO [Authorization number] and applicable for part number AVE-WPR-51G-401 and AVE-WPG-51G-402.

Compiled by: _____ 3. – Jul - 2017
Petr Jaroš
Engineer, Aveo Engineering Group, s.r.o.

Approved by: _____ 3. – Jul - 2017
Georg Hartl
Head of DO, Aveo Engineering Group, s.r.o.

0.3 Amendment Record procedure

The master copy of this document shall be kept electronically as a read only document under the control of Aveo Engineering Group, s.r.o. as Master Copy.

ALL amendments to this manual will initiate a raise of Issue

ALL raises of issue will be given a sequential Alphabetic Issue Ident sequentially from 01 to 99 in Table 01 - **Issue No:** Column– Initial Issue of Document will be **"01"**

ALL Issues of this document will be approved by Head of DO

Issue No.	Details	Date	Effectuated Pages
01	Initial Issue	26.Jun.2015	ALL
02	Update table of content Voltage values changed, Technical Specification upgraded	20.Jul.2015	2 5, 6 & 8
03	New Technical drawing with higher clearance in attaching holes (not marked), spec of installing screws added	3.Jul. 2017	7 & 9

Table 01: Document Amendment Record Table

0.4 Effected Pages Procedure

ALL pages affected by ANY raise of issue of this manual will be listed in Table 01 - *Effected Pages* Column.

The reason(s) for ALL raise of issue and description of change due to raise of issue will be provided for ALL raises of issue in Table 01 - *Details* Column.

Changes from the previous issue are highlighted by **YELLOW HIGHLIGHTING** over new content. AND **YELLOW HIGHLIGHTING** AND CROSSING OUT of deleted content.

Example **(CROSSING OUT)**

0.5 Distribution List

As stated in 0.3 above; the master copy of this document shall be kept electronically as a read only document under the control of Aveo Engineering Group, s.r.o. as Master Copy.

All holders of copies of this Document will be recorded by listing in Table 02 – Distribution List.

Copy holders listed will be issued a copy of this document with sequential copy number as shown in Table 02 – Distribution List

Copy No.	Holder
MASTER	Aveo Engineering Group, s.r.o.
Table 02: Distribution List	

1. Nebulon™

Nebulon™ is a LED position light assembly ETSO Compliant red and green position lights, low drag and low profile designed for aircraft wing position light. This powerful LED lighting system features easy installation, fail safe system, unbreakable construction, waterproof and high candela output

List of the major components (by part number) that make up the equipment complying with the standards prescribed in ETSO.

- **Nebulon™** PN : AVE-WPR-51G-401 (Red)
: AVE-WPG-51G-402 (Green)

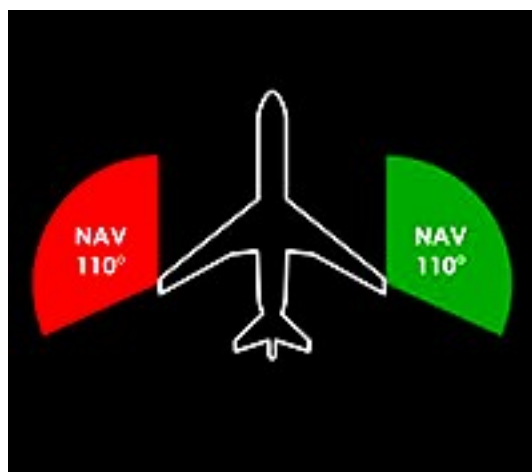
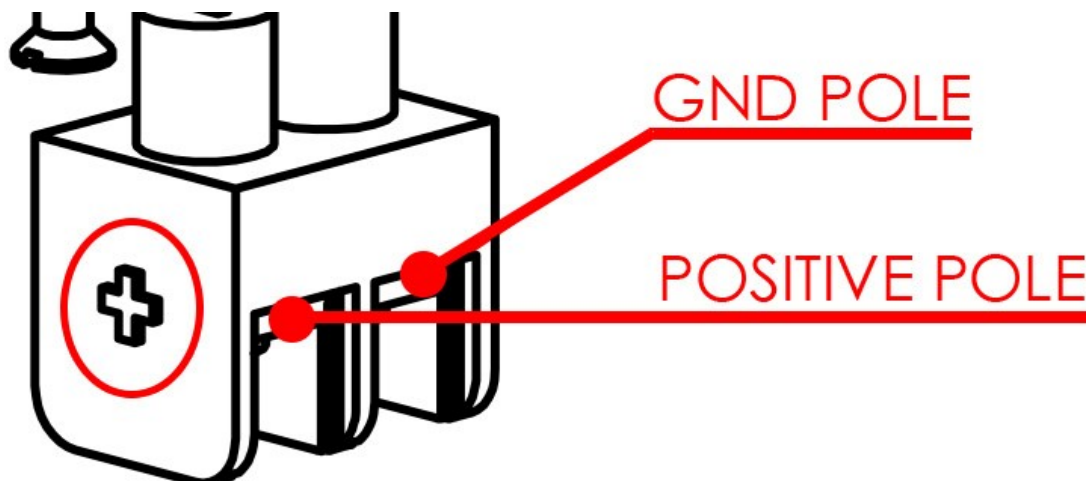

Figure 01: Features of Nebulon

2. OPERATING INSTRUCTIONS

When installed on the aircraft, using the aircraft's power (28 volts), the light will be at its maximum intensity. *(Meet the requirement of TSO-C30C, Aircraft Position Light)*

3. INSTALLATION SCHEMATIC / WIRING DIAGRAM



4. CONTROL & POWER INPUT'S:

POSITIVE POLE Positive POS/NAV power supply line
GND POLE Negative common power supply line (ground)

5. TECHNICAL SPECIFICATION

Dimensions (mm):	48 x 54 x 70
Dimensions (inches):	1.89" x 2.12" x 2.74"
Weight (g):	70g
Operating voltage:	18-36V
DC Primary input voltage:	28V
DC Over-voltage protection:	80V
(1s)	
Input current at 28V:	0.27A (+/- 10%)
Reverse polarity protection:	YES
Over-Voltage shut down:	38.5V
DC Under-Voltage protection:	YES
Operating temperature:	-55°C to +85°C
Over-Temperature protection:	YES
Output power	5.9W – Green 6.0W – Red
Waterproof:	YES
Vibration-proof:	YES
Shock-proof:	YES
Dust-proof:	YES

6. TECHNICAL DRAWING

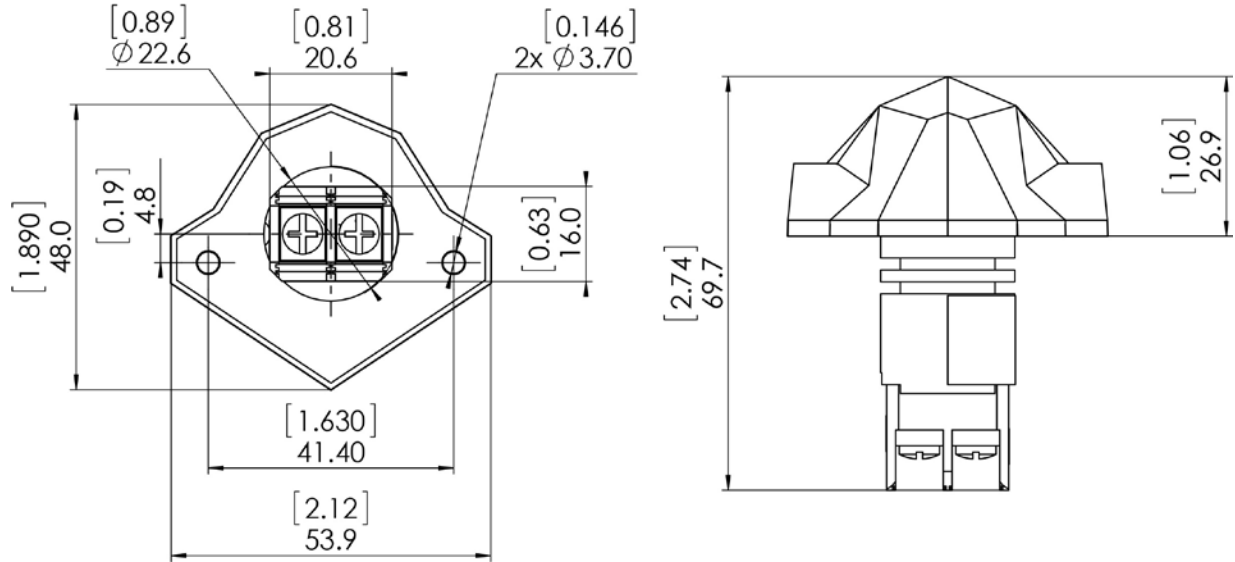

Dimensions are in millimeters / [inches]

7. WIRING CHART

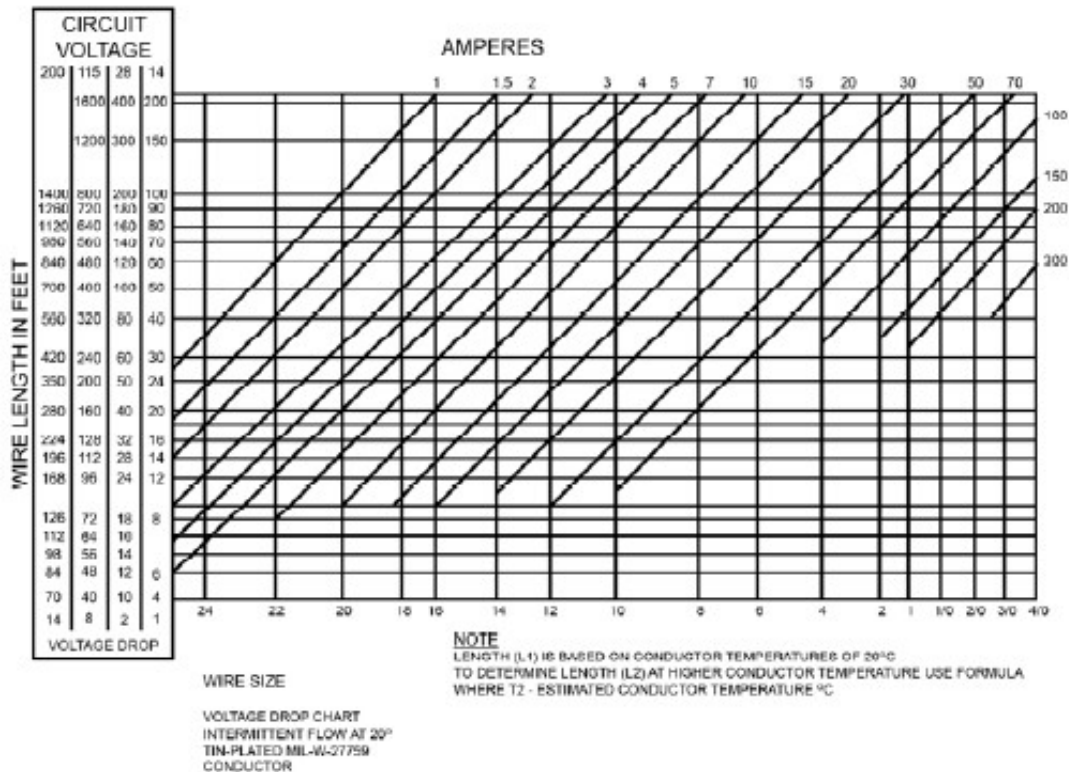

8. EQUIPMENT LIMITATION

Nebulon™ should only be powered by 18-36 Vdc, typically a 24 volt aircraft battery.

9. TESTING OF THE LIGHT BEFORE INSTALLATION

All Aveo Aviation lights undergo rigorous testing prior to being released from our engineering manufacturing department. This testing involves a burn-in time as well as other function testing. No light is released for sale without undergoing this extensive operational testing.

When you receive the **Nebulon™** light, and wish to test the function of the light prior to installation on your aircraft, please note the following:

1. Please review the written information that is enclosed in the packaging. Warranty information as well as a cautionary note about power supply removal is enclosed with each package.
2. Remove the light from the package. Note that there is connector with:
 - Negative lead
 - Positive lead
3. Testing of the function of the light can be done with a regular 28V/5A dc power supply (not a battery charger). Connect the negative pole to the ground (negative) leads of a power supply, and then connect the positive pole to the positive (+) leads on the power supply. The position light should start lighting. When installed on the aircraft, using the aircraft's power (28 volts), the light will be at its maximum intensity.

After testing, the light can be installed on the aircraft.

IMPORTANT NOTES:

1. Under no circumstances should any power supply other than a 18-36 Vdc, or a 24 volt battery be used to test the light. Do not use: Battery chargers, battery back-up power devices, or other bench avionics testing methods to test the aviation light. The light is functional between 18 and 36 volts. Use of a battery charger or other power unit to test the light will void the warranty and may damage the light.

If you have any questions about the installation of the lights, please refer to our web site: www.aveoengineering.com, and check FAQ and other links on our aviation lights web page.

10. CARE AND CLEANING OF YOUR AVEO ENGINEERING AVIATION LIGHTS

When you receive your Aveo Engineering Aviation Lights, they will have been factory polished and ready to install on the aircraft. Upon installation, just give the lights a good coat or two of a quality automotive polish. This should protect the lights from dirt and other environmental factors. Once or twice a month, just refresh the polish and hand buff to bring back the lights to factory like new condition.

If the lights need a deeper cleaning, they can be polished with a good automotive cleaner wax and/or a liquid polishing compound. The liquid polishing compounds can normally be found at automotive parts stores or an automotive paint store. After using a polishing compound, just give the lights another coat of an automotive polish and you will again protect the lights against dirt, etc. An electric buffing machine, with a lamb's wool cover, can also be used for deeper cleaning and polishing. Under no circumstances should any petroleum based product be used to clean the lights.

~~For continued UV protection Aveo Engineering offers Nonocloak™ UV Protectant Spray and Cleaner, available at any Aveo Engineering Authorized installation Center.~~

11. NOTES ON INSTALLATION

Spread the tightening forces evenly around the mounting hole. **Lights are to be installed using MS35206-232 screws or equivalent.**

12. CONTINUED AIRWORTHINESS INFORMATION

This product is delivered with EASA Form1 which is for the operator to report any occurrences to Aveo Engineering as the ETSO holder. The form contains the Aveo Engineering telephone number and the occurrence e-mail address (occurrence@aveoengineering.com). **The operator must report immediately** as the ETSO holder must report occurrences having a potential for an unsafe condition within 72 hours.

a. *Circuit/Wiring Protection*

Each Galactica series light features a **Negative Temperature Coefficient** (NTC) circuit that limits internal temperatures by attenuating operating current (with a corresponding reduction of brightness) when internal temperatures reach a certain threshold. This proprietary

circuitry serves to protect the light itself, and associated aircraft wiring, against a thermal runaway condition.

b. Periodic Inspection Procedure for Galactica Series

The **Nebulon™** lights should always be checked for proper operation during preflight. This procedural information is already provided in all general aviation aircraft flight manuals.

The lights should be visually inspected for general condition, proper operation, and correct installation at each annual and/or 100 hour inspection. Any debris or atmospheric deposits accumulated on the surface of the lights should be removed using a UV Wax such as Farecia Profile UV Wax to ensure ongoing optical clarity. In addition refer to section 10 of installation manual for detailed cleaning instructions.

Turn the lights and do the following:

1. Put on polarized sunglasses or welder goggles to prevent eye damage when looking into the lights.
2. Examine the individual LEDs as per the diagram below. If any of the conditions as indicated on the diagram are exceeded, the light shall be removed and sent to Aveo Engineering for replacement under the Aveo Lifetime Warranty Program.

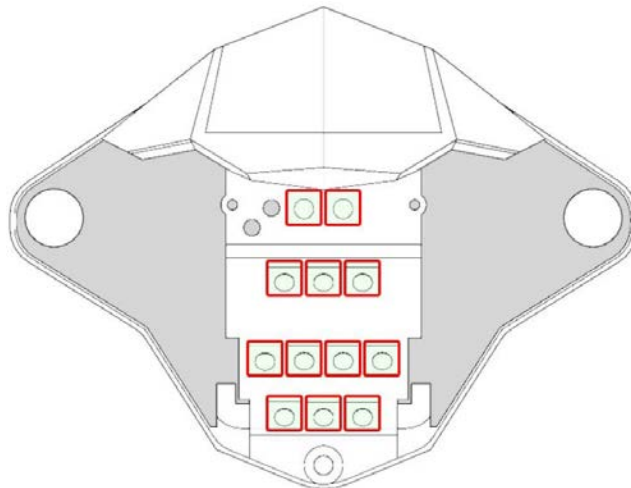

Figure 1: Navigation LEDs – all LEDs (12 pcs)