

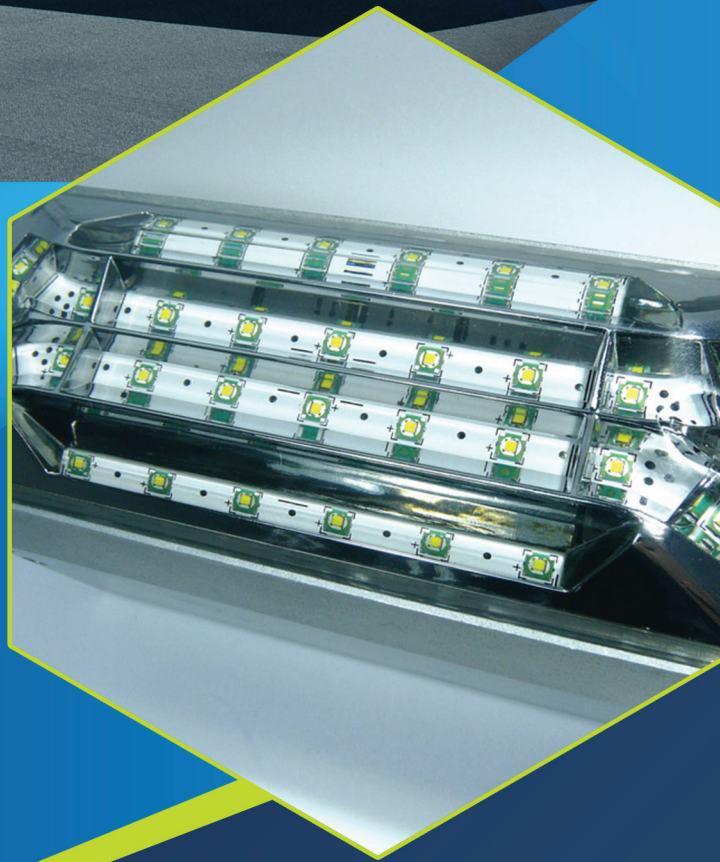

SmartStrobe™

Wingtip Strobe Replacement



Basics

Replacing the problematic, unreliable and really ugly legacy strobe light in the wingtip of Gulfstream IV's and V's was one of the first requests. Of course, the entire project was limited by the drop-in replacement requirement, so making the trademark sleekest light designs was not possible on most of these retrofit lights, but still the result was a cool appearance, a lighter weight product, a brighter light, and more reliable strobe with the amazing live status indicators of Aveo's built-in LEDCheck™ system.

Functional replacement for the following platforms & parts:

Gulfstream GV

Honeywell 30-2446 (Strobe light)

Honeywell 60-4943 (Strobe power supply)

Specification

Certification	ETSO and STC Pending
Qualification	Fully qualified to DO-160D
Input voltage	90-130V AC, 360-440 Hz
Input current	0.75A
Operating temperature	-40°C to +85°C
Over-temperature protection	Yes
Output power	45W peak
Waterproof	Yes
Vibration-proof	Yes
Shock-proof	Yes
Dust-proof	Yes
Weight	1.278 lbs / 580g
Width	2.402" / 61mm
Length	5.635" / 143mm
Height	2.74" / 69.7
Warranted life to FAR specifications	Lifetime warranty

Drawing

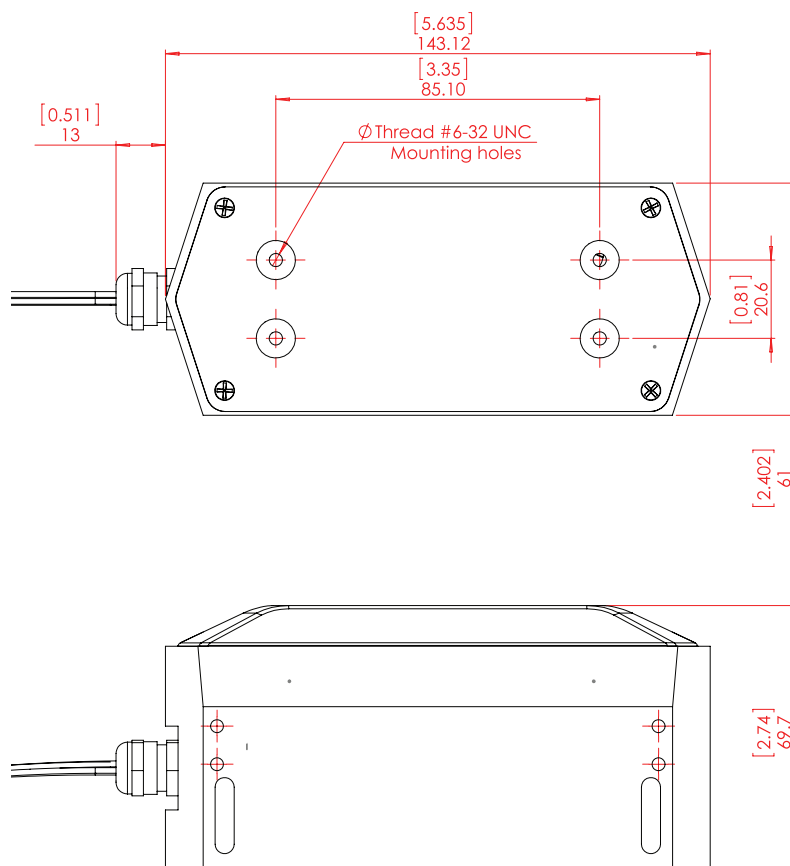

Brilliantly Different!

AVEO
ENGINEERING