



INSTALLATION MANUAL

## RedBaron Combo HISL 1000

Anti-collision LED Light

**AEF-RBH1ACWR-IM**

## Table of Contents

<b>PART 0</b>	<b>DOCUMENT ADMINISTRATION .....</b>	<b>3</b>
0.1	DOCUMENT APPROVAL .....	3
0.2	AMENDMENT RECORD PROCEDURE .....	4
0.3	EFFECTED PAGES PROCEDURE .....	4
<b>PART 1</b>	<b>INSTALLATION DATA .....</b>	<b>5</b>
1.1	PRODUCT INFO .....	5
1.2	OPERATING INSTRUCTIONS .....	5
1.3	INSTALLATION SCHEMATIC / WIRING DIAGRAM .....	6
1.4	CONTROL & POWER INPUTS .....	6
1.5	TECHNICAL SPECIFICATION .....	6
1.6	TECHNICAL DRAWING .....	8
1.7	WIRING CHART .....	9
1.8	OPTIC SIMULATION .....	10
1.8.1	RedBaron Combo HISL 1000 – White section.....	10
1.8.2	RedBaron Combo HISL 1000 – Red section .....	15
1.9	EQUIPMENT LIMITATION .....	20
1.10	CARE AND CLEANING OF LIGHTS .....	20
1.11	TESTING OF THE LIGHT BEFORE INSTALLATION .....	20
1.12	NOTES ON INSTALLATION .....	21
1.13	ETSO REQUIREMENT DEVIATION .....	21
1.14	CONTINUED AIRWORTHINESS INFORMATION .....	21
1.15	ROHS COMPLIANCE STATEMENT .....	22
1.16	EU REACH REGULATION (EC) No. 1907/2006 .....	23

## Part 0 Document Administration

### 0.1 Document approval

This installation manual is applicable for following part numbers:

- **RedBaron Combo HISL 1000** AVE-RBH1ACWR-T01 Mod()

  
Compiled by: \_\_\_\_\_ 15. November 2024  
Petr Jaroš  
Engineer, Aveo Engineering Group, s.r.o.

  
Approved by: \_\_\_\_\_ 15. November 2024  
Georg Hartl  
Head of DO, Aveo Engineering Group, s.r.o.

## 0.2 Amendment Record procedure

The master copy of this document shall be kept electronically as a read only document under the control of Aveo Engineering Group, s.r.o. as Master Copy.

ALL amendments to this manual will initiate a raise of issue.

The original issue will be identified by "01", and subsequent issues will be numbered sequentially from 02 to 99 in Table 01 - Issue No. column.

ALL issues of this document will be approved by Head of DO.

Issue No.	Details	Date	Affected Pages
01	Initial Issue	15.Nov.2024	ALL
<b>Table 01: Document Amendment Record Table</b>			

## 0.3 Affected Pages Procedure

ALL pages affected by ANY raise of issue of this document will be listed in Table 01 - **Affected Pages** Column.

The reason(s) for **EACH** raise of issue and the description of respective change will be provided in Table 01 - **Details** Column.

Changes from the previous issue are shown as follows:

- a) new text is highlighted with yellow shading: **new**
- b) deleted text is shown with yellow shading and a strike through: ~~**deleted**~~

## **Part 1 Installation data**

### **1.1 Product Info**

- **RedBaron Combo HISL 1000                      AVE-RBH1ACWR-T01 Mod()**

Introducing the Aveo RedBaron Combo HISL 1000™, a light designed to far exceed the new requirements for power line and pipeline helicopter inspection operations, and the world's brightest HISL Anti-collision light period. If you operate in bad weather, or night operations over urban areas with intense ground light below, or you just want to be sure you are seen, then there is only one light in the world for your helicopter, the RedBaron Combo HISL 1000™. Nothing else in the industry comes close! The RedBaron Combo HISL 1000™ features the world's highest output LEDs, chromaticity compliant and intensity far exceeding the aerospace TSO regulations worldwide. Unmatched, groundbreaking optical performance in both red and white sections, and it is a Drop-In replacement for legacy anticollision lights. No external power boxes, everything is already inside, so great weight savings too!

The incredible and unmatched performance of the RedBaron Combo dual-color LED red and white anti-collision light makes it not only the world's brightest but also the leader in all DO-160 environmental standards compliance.

Main Features:

- Selectable modes of two switches, white or red (RedBaron Combo HISL 1000 can be only operated in EITHER RED or WHITE MODE, not simultaneously or it will damage the unit)
- Unmatched strobe intensity in the industry
- Incorporates the world-leading lumen output LED technology
- Low profile and vibration-proof, shock-proof and water-proof design unmatched in the industry
- No external power boxes

### **1.2 Operating Instructions**

When installed on the aircraft, using the aircraft's power (28 volts), the light will be at its maximum intensity.

*Operating Voltage range is +18...+36VDC.*

## 1.3 Installation Schematic / Wiring Diagram

Connector PN: MS3102R10SL-3P

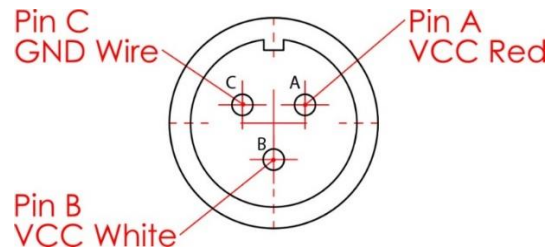

## 1.4 Control & Power Inputs

**PIN A:** VCC Red  
**PIN B:** VCC White  
**PIN C:** GND Wire

## 1.5 Technical Specification

<b>Dimensions:</b>	See Technical Drawing in Section 1.6
<b>Weight (max):</b>	0.365 kg / 0.8 lb
<b>Operating Voltage Range:</b>	18 – 36 VDC
<b>Voltage protection:</b>	a. Transient voltage: 2 seconds +80VDC b. Under-voltage lockout: +17VDC, not more c. Over-voltage lockout: +36.7VDC, not less
<b>Repetition Flash Rate of Strobe:</b>	48 flash patterns per minute (96 strobes per min.) The strobe pattern is 0.3 s long and due to that the last strobe is considered separate, leading to a strobe count of 96 strobes per minute.
<b>Ambient temperature:</b>	-55°C...+85°C / -67°F...+185°F
<b>Overheat protection:</b>	75°C / 167°F
<b>Exceed requirements of:</b>	- TSO C96b - SAE AS8017D <ul style="list-style-type: none"> <li>• White Strobe meets AS8017D Class II &amp; Class III</li> <li>• Red Strobe meets AS8017D Class I, Class II &amp; Class III</li> </ul> - DO-160G - MIL-DTL-7989
<b>Recommended size of mounting screw:</b>	Screw M3x12 DIN 912 (AVS-11430903012)

**Performance:**

	<b>Input Power (Peak):</b>	<b>Input Current (Peak):</b>
<b>WHITE Strobe Branch</b>	<b>52.5W @28V</b>	<b>1.88A @28V</b>
<b>RED Strobe Branch</b>	<b>45.9W @28V</b>	<b>1.64A @28V</b>

**Device RTCA/DO160G qualified:**

<b>Environment</b>	<b>Section</b>	<b>Category</b>
Temperature / Altitude	4	F2
Temperature Variation	5	A
Humidity	6	C
Temperature Shock	MIL-DTL-7989	B
Operational Shock and Crash Safety	7	B*
Vibration	8	U curve G
Waterproofness	10	S
Fluids Susceptibility	11	F**
Sand and dust	12	D
Fungus	13	F
Salt Fog	14	T
Magnetics Effects	15	Z
Power Input	16	BRX
Voltage Spike	17	A
Audio Freq. Conducted Susceptibility	18	Z
Induced Signal Susceptibility	19	AC
Radiated and Conducted Susceptibility	20	TT
Radiated and Conducted Emissions	21	H
Lightning Induced Transient Susceptibility	22	A2E2X
Lightning Direct Effects	23	not evaluated***
Icing	24	A
Electrostatic Discharge	25	A
Fire, Flammability	26	C

\* Aircraft Type: 5. Helicopters and All Fixed-wing, Test Type R, 20.0g all direction

\*\*Actual fluids: Jet A-1 aviation fuel, Mobil Jet Oil II, Ethylene glycol de-icing fluid  
\*\*\* Lightning Direct Effects are not tested for TSO as they must be tested per applicable zones for each individual airframe, which Aveo does when it applies for FAA STC/EASA MODs for installation approval on each platform. Actual examples of these tests including reports from Lightning Labs and Videos of the actual tests are available for example at:

[https://www.aveoengineering.com/Aveo-download\\_WS1002/Aveo-lightning-strike-test.zip](https://www.aveoengineering.com/Aveo-download_WS1002/Aveo-lightning-strike-test.zip)

## 1.6 Technical Drawing

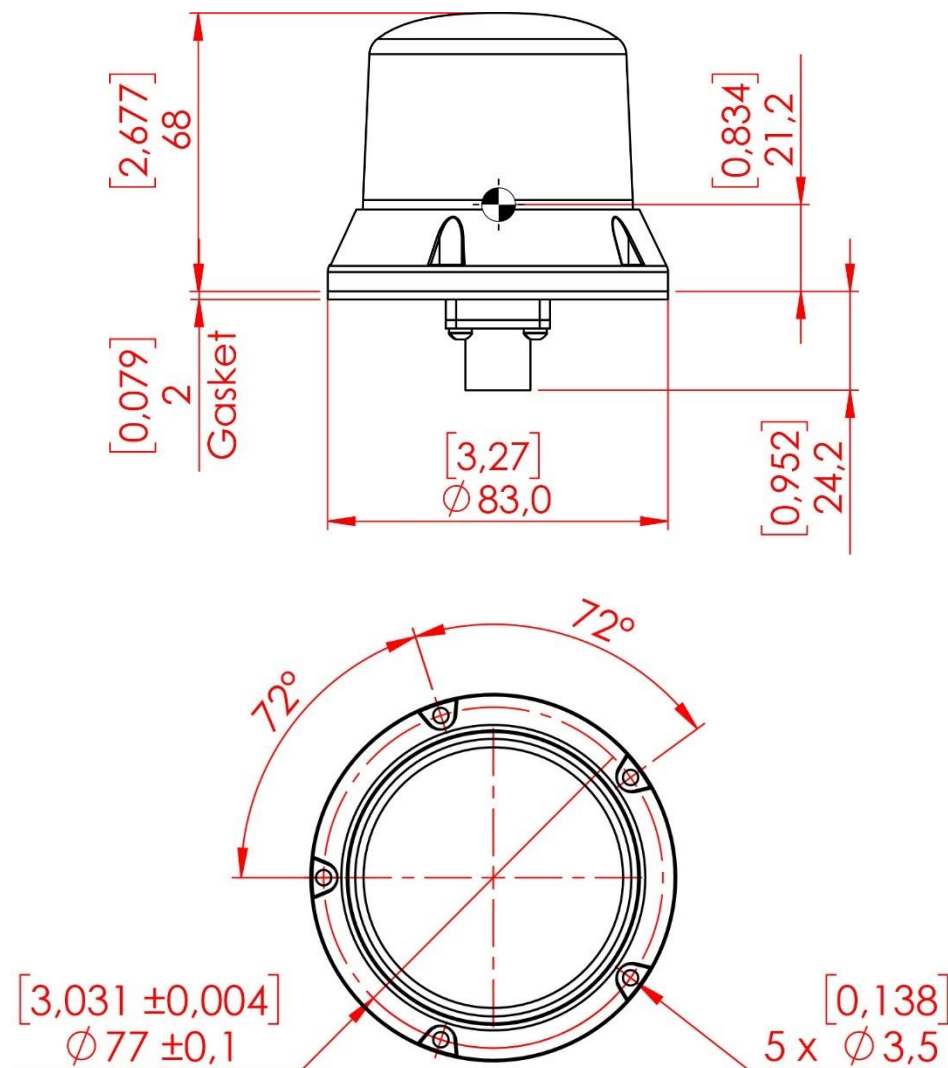

*Dimensions in [inches] mm*



## 1.7 Wiring Chart

Use diagram below defining the wiring size depending on the current and the wire length. Make sure you add up the current for all connected lights. If current is not given, then divide the power by the voltage.

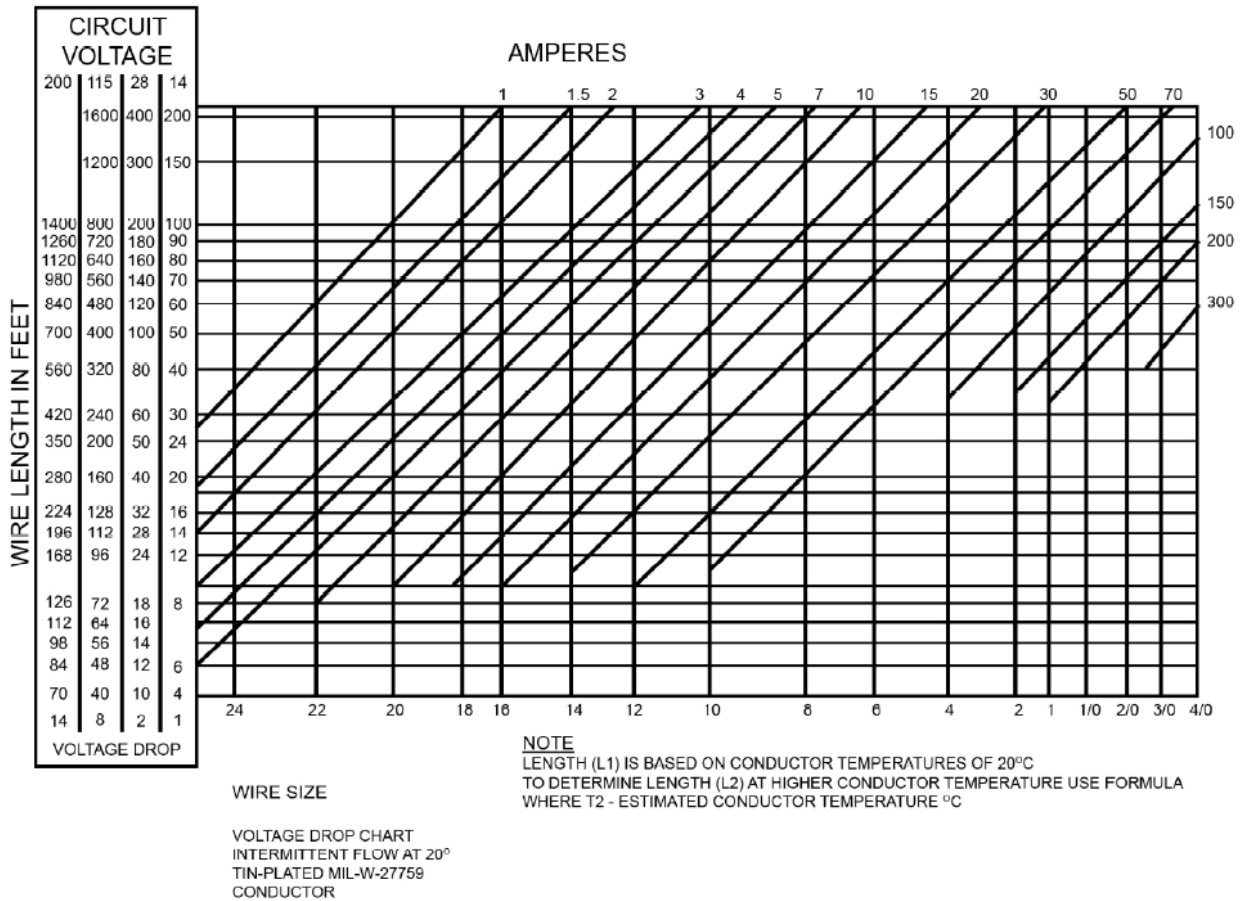

## 1.8 Optic Simulation

### 1.8.1 RedBaron Combo HISL 1000 – White section

<b>Output lumens:</b>	3161 lm
<b>Peak intensity:</b>	770 cd
<b>Input Voltage:</b>	28 V
<b>Input Current (start):</b>	1.910 A
<b>Input Current (finish):</b>	1.905 A

Aircraft Horizontal Plane, "0" direction is HOV0 FWD. Full range, Ecd

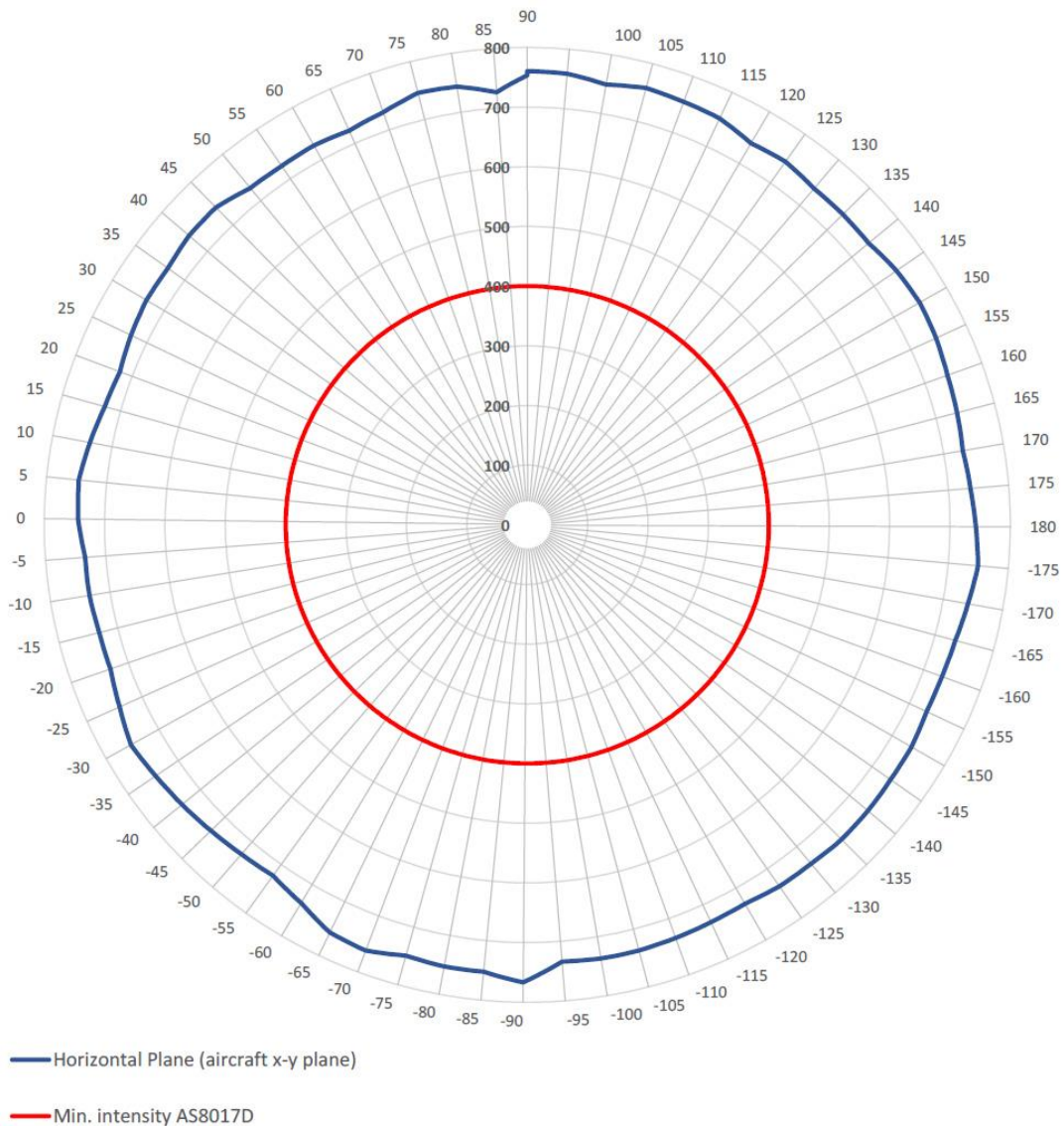

Vertical Planes (Horizontal 0°-180° and Horizontal 90° - 270°). Full range, Ecd

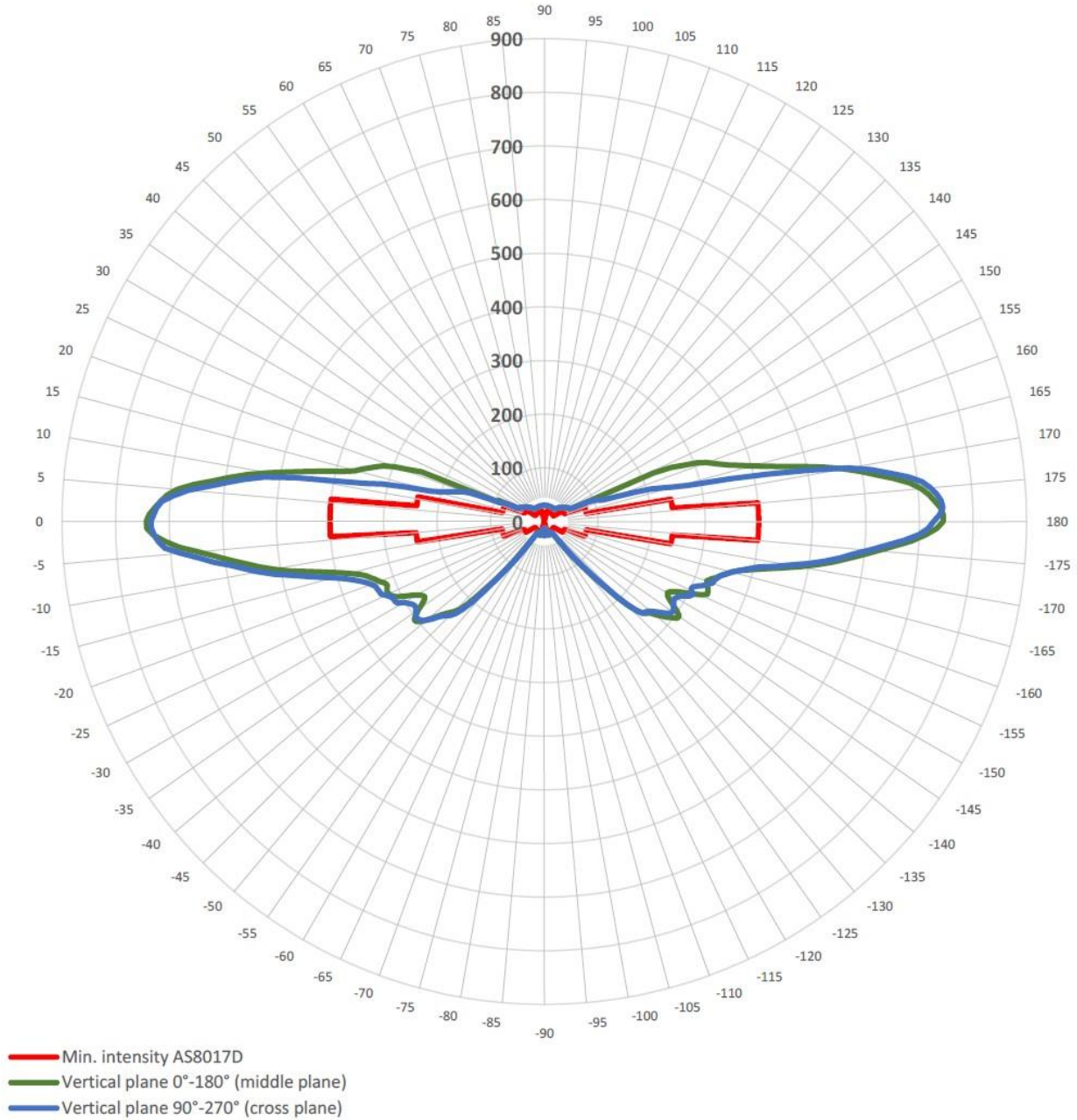

Vertical Planes (Horizontal 0°-180° and Horizontal 90° - 270°). Partial range 0-450 Ecd

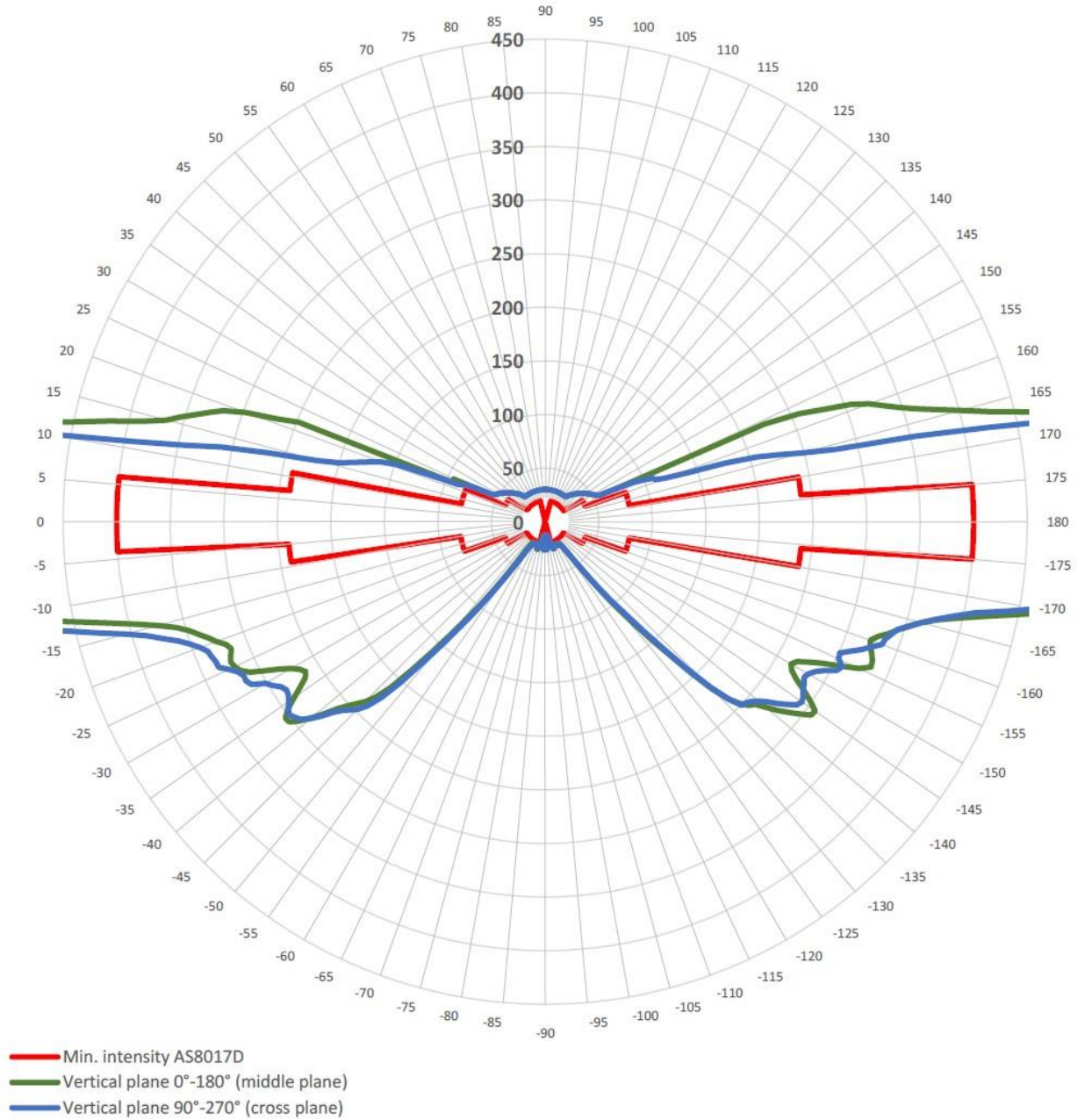



Vertical Planes (Horizontal 0°-180° and Horizontal 90° - 270°). Full range, Ecd

Grey lines show values of inclination in each of azimuth angle.

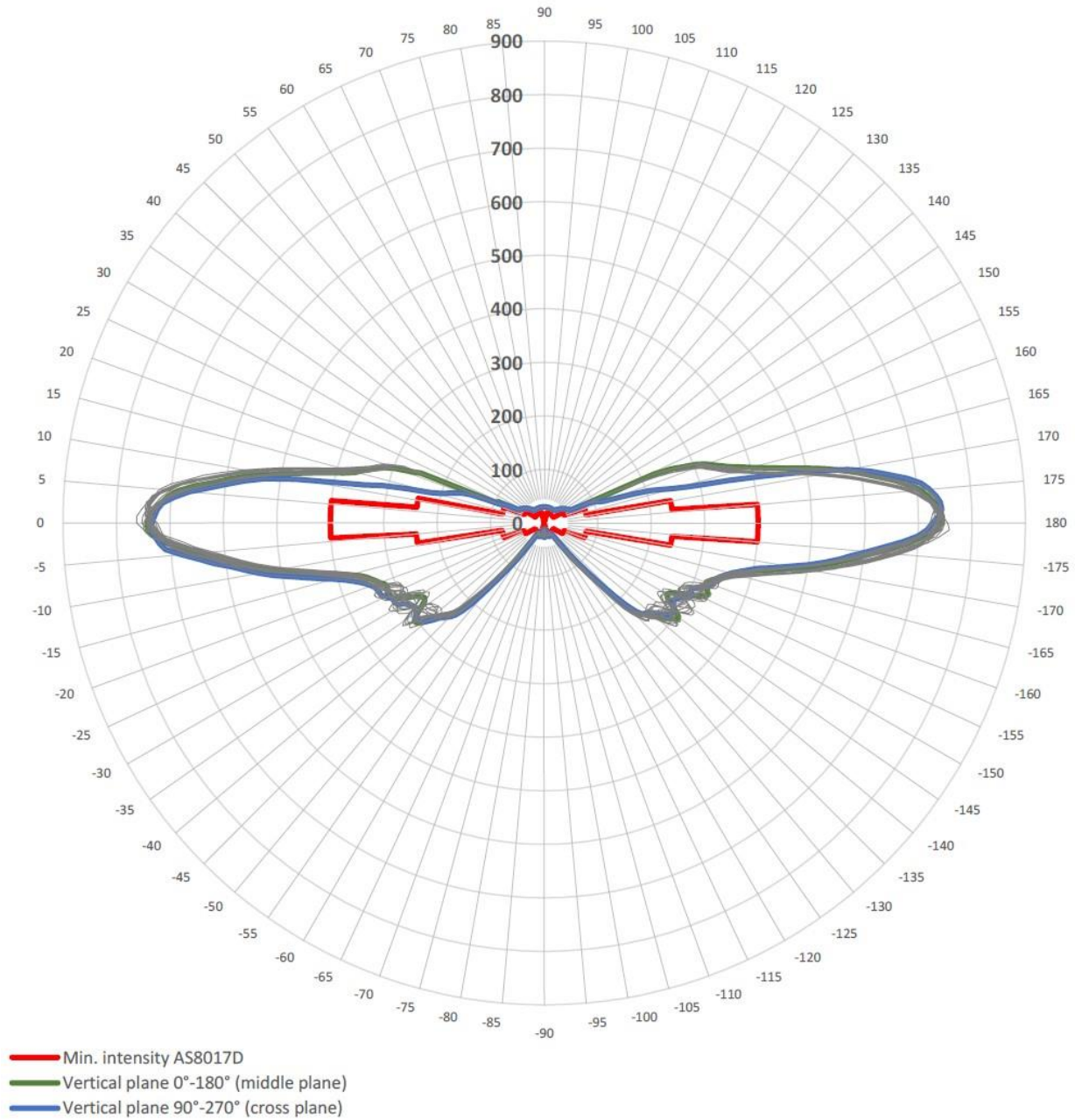

Vertical Planes (Horizontal 0°-180° and Horizontal 90° - 270°). Partial range 0-450 Ecd

Grey lines show values of inclination in each of azimuth angle.

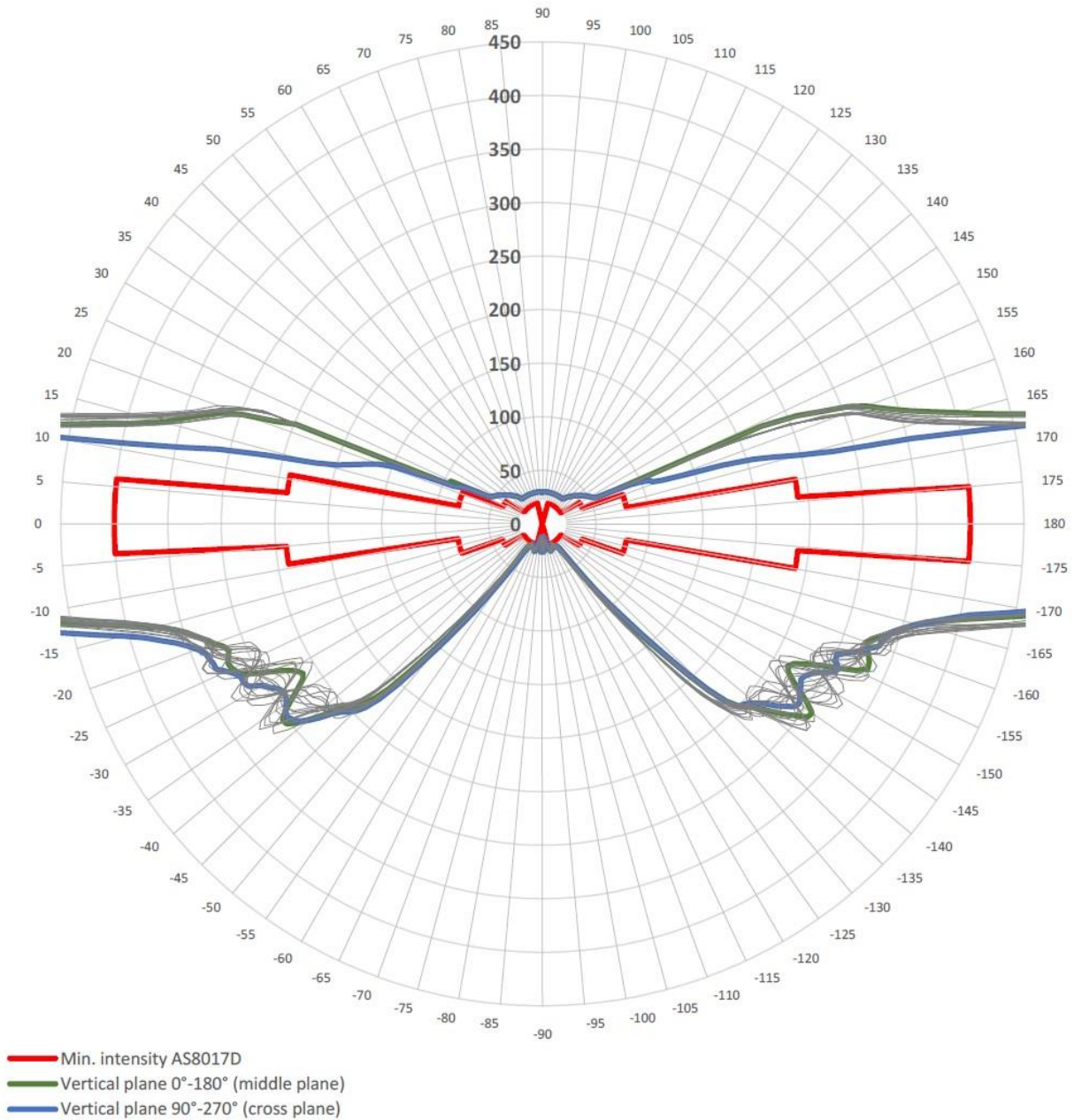

### 1.8.2 RedBaron Combo HISL 1000 – Red section

<b>Output lumens:</b>	1490 lm
<b>Peak intensity:</b>	557 cd
<b>Input Voltage:</b>	28 V
<b>Input Current (start):</b>	1.715 A
<b>Input Current (finish):</b>	1.670 A

Aircraft Horizontal Plane, "0" direction is HOVO FWD. Full range, Ecd

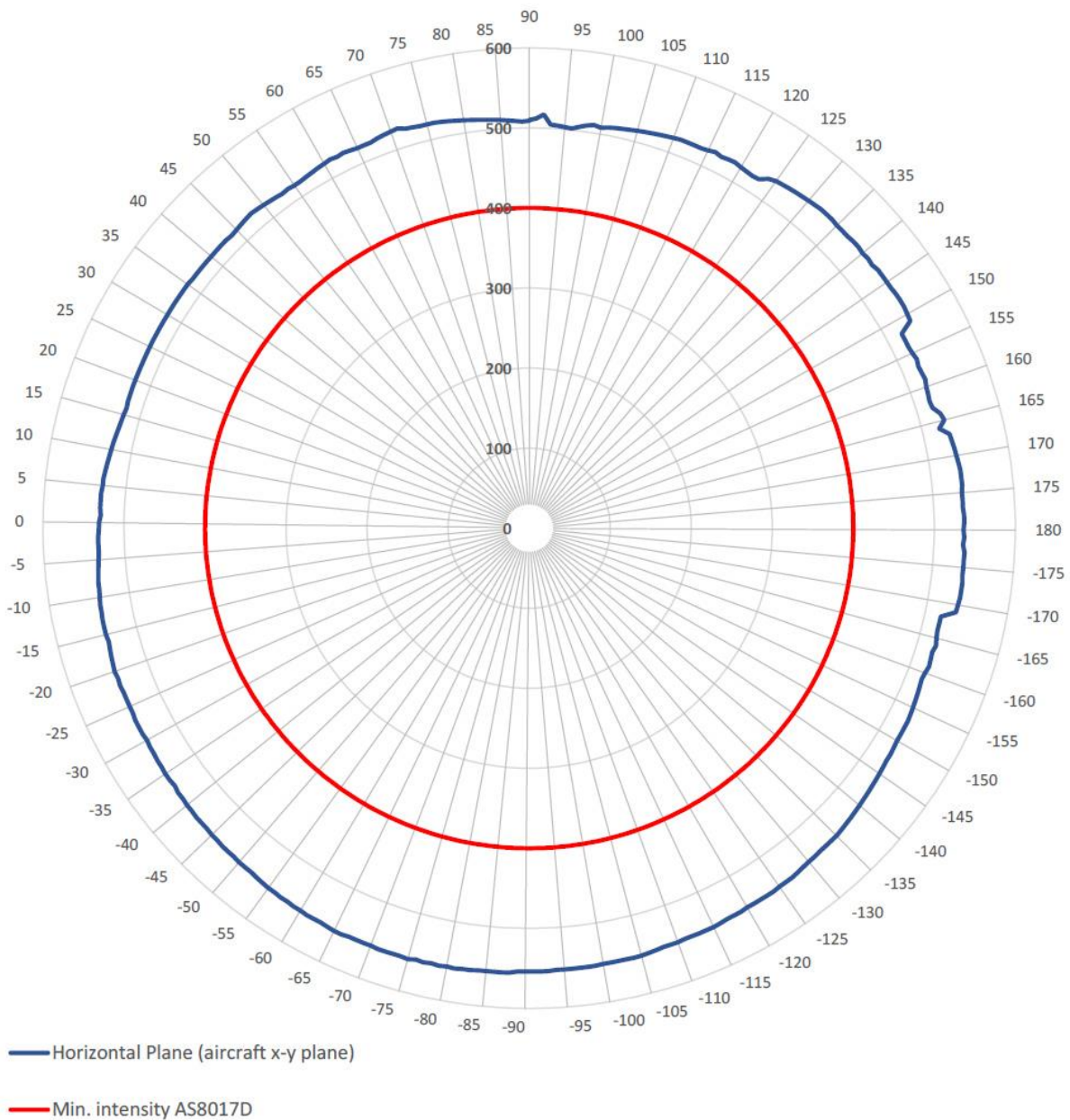



Vertical Planes (Horizontal 0°-180° and Horizontal 90° - 270°). Full range, Ecd

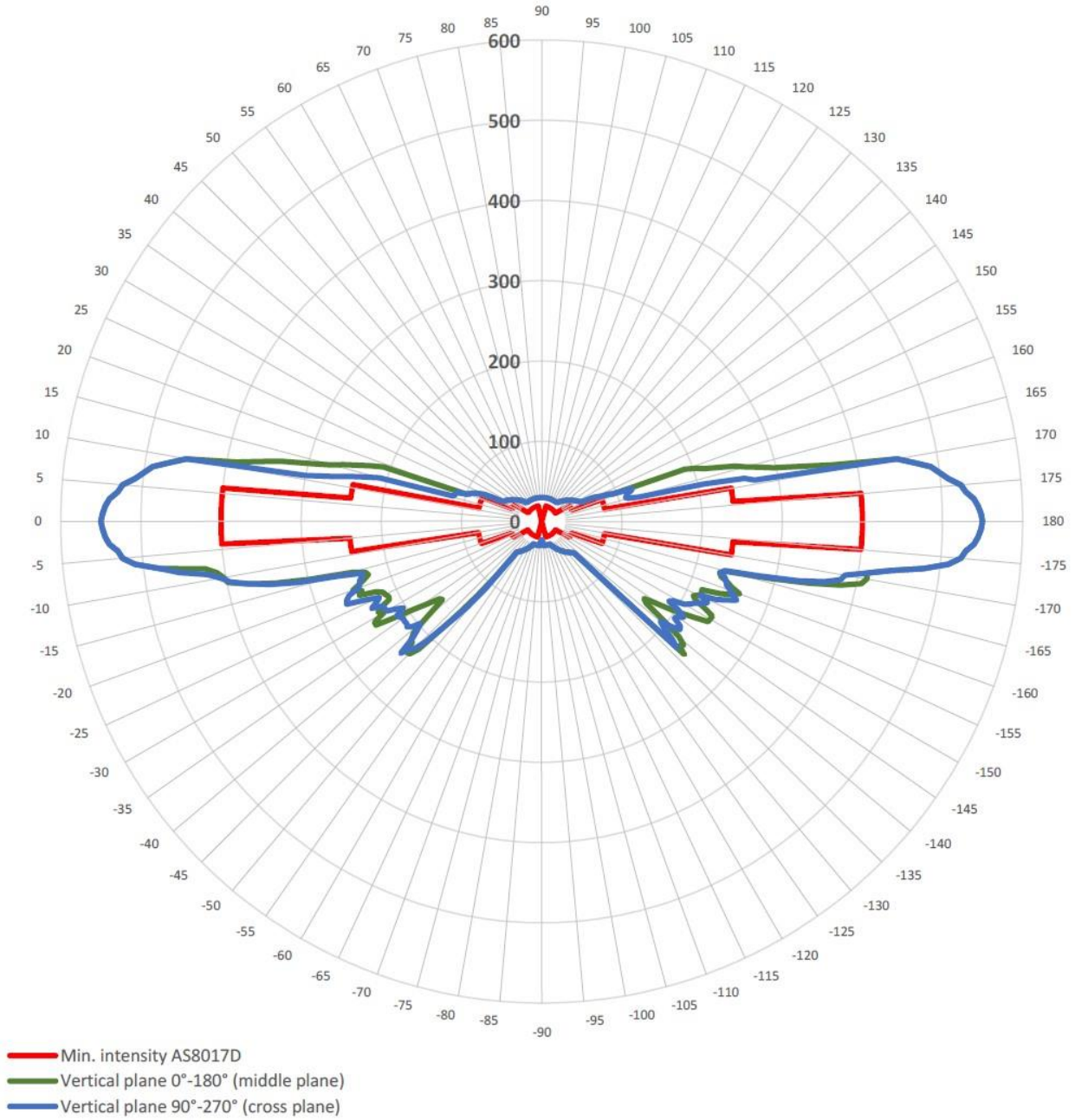



Vertical Planes (Horizontal 0°-180° and Horizontal 90° - 270°). Partial range 0-450 Ecd

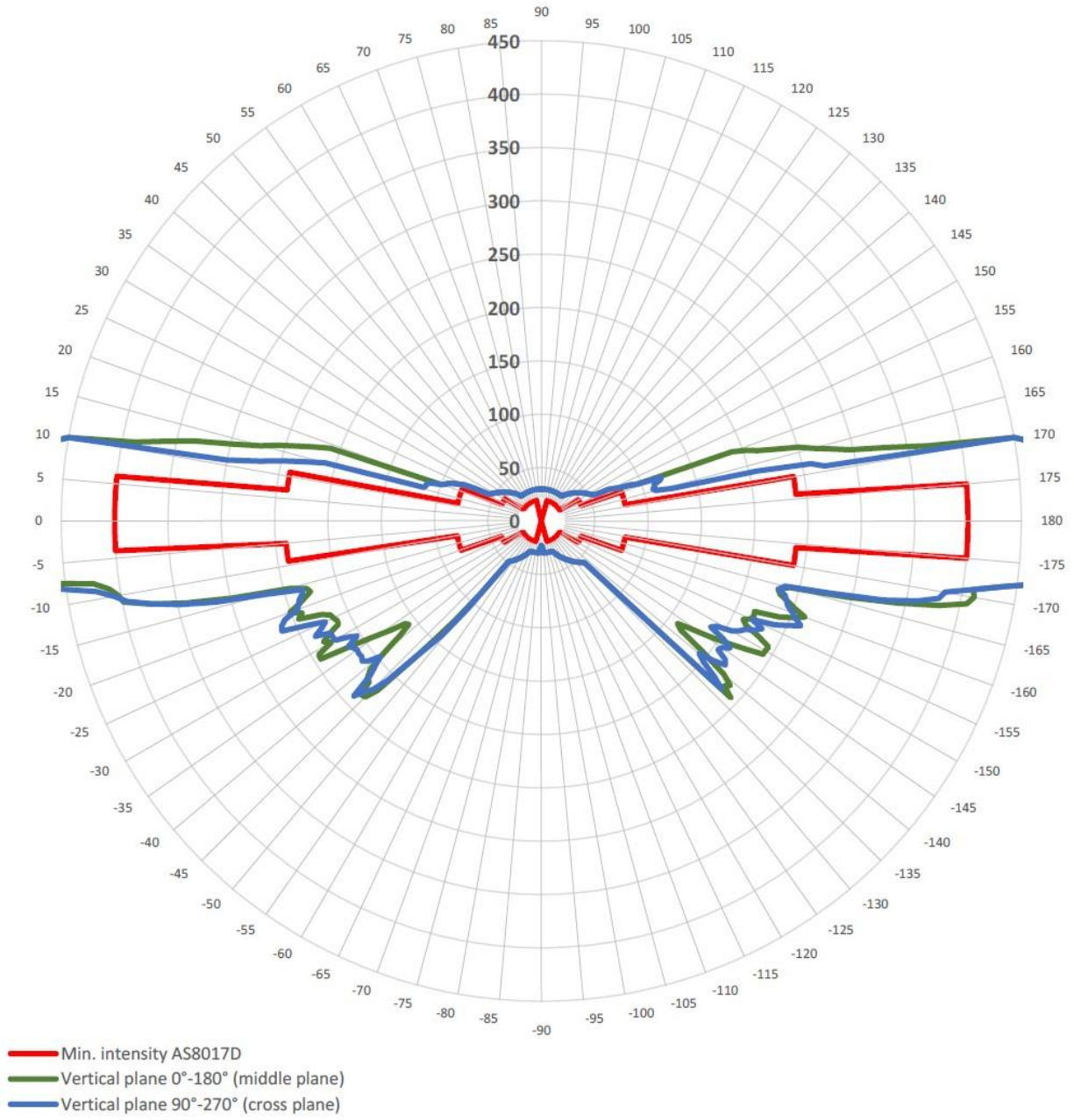

Vertical Planes (Horizontal 0°-180° and Horizontal 90° - 270°). Full range, Ecd

Grey lines show values of inclination in each of azimuth angle.

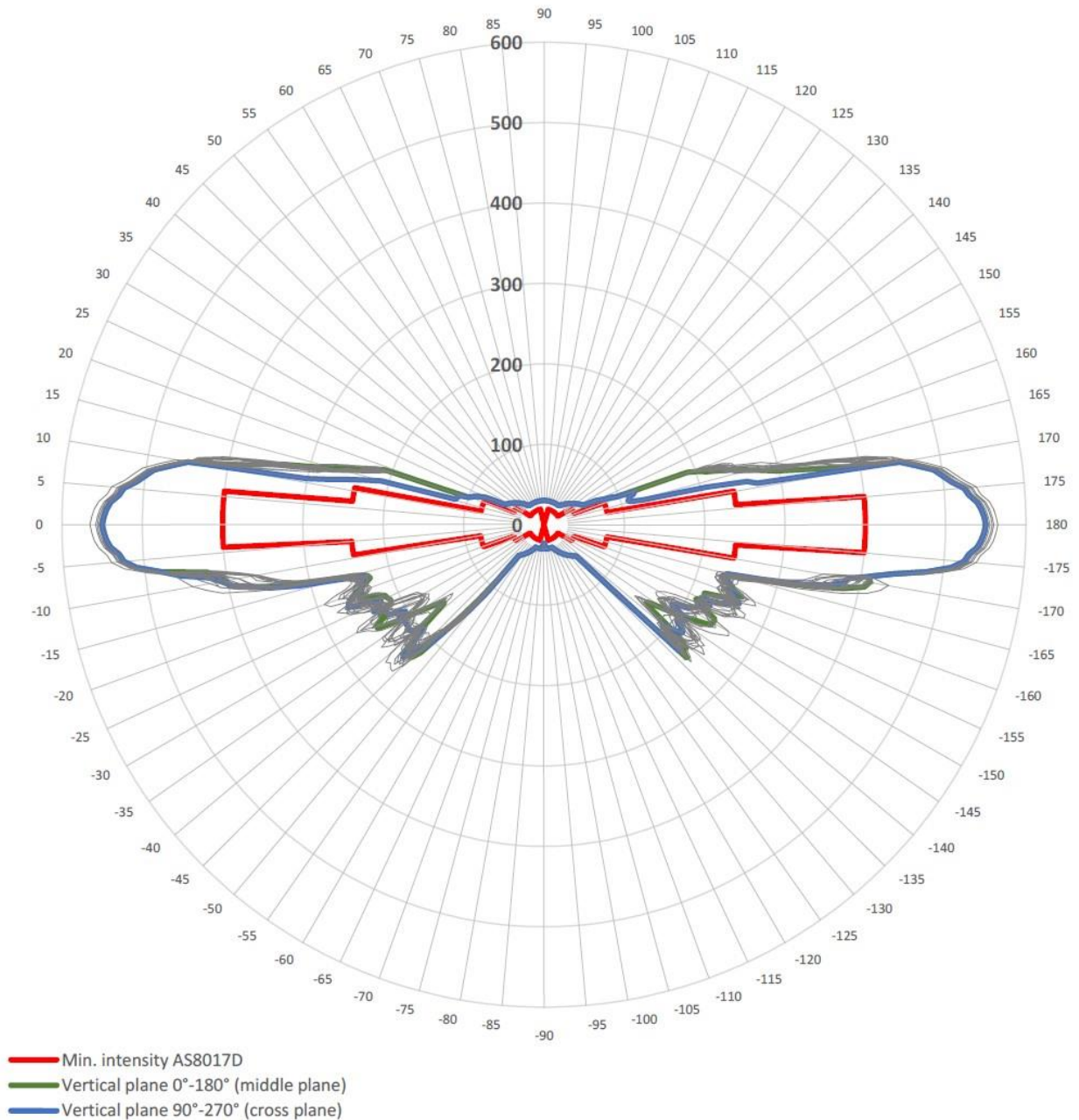

Vertical Planes (Horizontal 0°-180° and Horizontal 90° - 270°). Partial range 0-450 Ecd

Grey lines show values of inclination in each of azimuth angle.

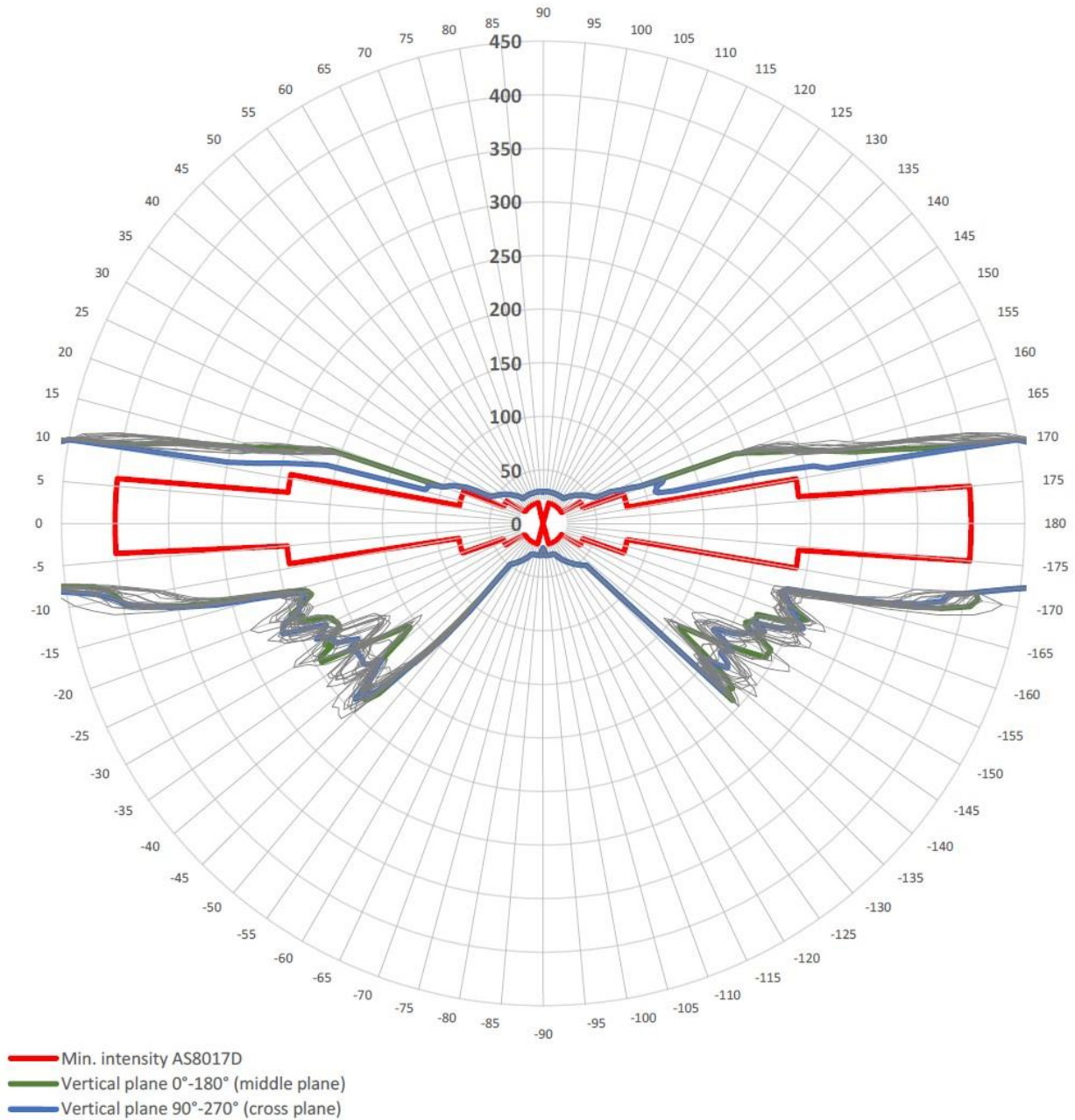

## **1.9 Equipment Limitation**

**RedBaron Combo HISL 1000** should only be powered by 18-36 VDC, typically 28 volt aircraft battery.

This article meets the minimum performance and quality control standards required by the technical standard order TSO C96b. Installation of this article requires separate approval.

### ***Deviations***

None

## **1.10 Care and Cleaning of Lights**

Aveo Engineering Aviation Lights are factory polished and delivered as ready to install on the aircraft.

If the lights need a deeper cleaning, they should be polished with a quality lamb's wool sheet that is suitable also for deeper polishing. Under no circumstances should any petroleum based product be used to clean the lights.

## **1.11 Testing of the Light Before Installation**

All Aveo Aviation lights undergo rigorous testing prior to being released from our engineering manufacturing department. This testing involves a burn-in time as well as other function testing. No light is released for sale without undergoing this extensive operational testing.

When you receive the Aveo **RedBaron Combo HISL 1000** light, and wish to test the function of the light prior to installation on your aircraft, please note the following:

1. Please review the written information that is enclosed in the packaging. Warranty information as well as a cautionary note about power supply removal is enclosed with each package.
2. Remove the light from the package. Note that there is a connector coming from the light. Pins description is also in the section 1.3 and 1.4.

PIN A:	VCC Red
PIN B:	VCC White
PIN C:	GND Wire

3. Testing of the function of the light can be done with a regular 28V DC power supply (not a battery charger).

Connect the PIN C to the ground (negative) leads of a power supply, then connect the PIN A to the positive (+) leads on the power supply. The anti-collision light should start flashing in red color. Disconnect PIN A. Then connect the PIN B to the positive (+) leads on the



power supply. The anti-collision light should start flashing in white color. Disconnect all wires. When installed on the aircraft, using the aircraft's power (28 volts), the light will be at its maximum intensity.

After testing, the light can be installed on the aircraft.

**IMPORTANT NOTES:**

1. Under no circumstances should any power supply other than a 18-36 VDC, or a 24-volt battery be used to test the light. Do not use: Battery chargers, battery back-up power devices, or other bench avionics testing methods to test the aviation light. The light is functional between 18 and 36 volts. Use of a battery charger or other power unit to test the light will void the warranty and may damage the light.
2. All power supplies for existing strobe lights, flasher beacons, etc. are required to be removed from the aircraft prior to the installation of the Aveo light.
3. RedBaron Combo HISL 1000 can be only operated in EITHER RED or WHITE MODE, not simultaneously or it will damage the unit.

If you have any questions about the installation of the lights, please refer to our web site: <https://www.aveoengineering.com>

## **1.12 Notes on Installation**

Please use Screw M3x12 DIN 912 (AVS-11430903012) or equivalent mounting screw for the installation. Spread the tightening forces evenly around the mounting hole. Stainless steel screw is recommended. Length depends upon placement location on aircraft.

## **1.13 ETSO Requirement Deviation**

Paragraph a. (1) through a. (3) of **TSO-C96b** requires the minimum performance standards (MPS) listed in SAE8017D and RTCA DO-160G. AVEO aviation light Part Number **AVE-RBH1ACWR-T01 Mod()** meets these standards without any deviation.

## **1.14 Continued Airworthiness Information**

This product is delivered with form F-AVE-001A which is for the operator to report any occurrences to Aveo Engineering as the TSO holder. The form contains the Aveo Engineering telephone number and the occurrence e-mail address).

**The operator must report immediately** as the TSO holder must report occurrences having a potential for an unsafe condition within 72 hours.

This is an LED light, which does not have an appreciable degradation over the life time, which is more than 30.000h.

### Periodic Inspection Procedure for RedBaron Combo HISL 1000 Series

The Aveo **RedBaron Combo HISL 1000** lights should always be checked for proper operation during pre-flight. This procedural information is already provided in all general aviation aircraft flight manuals.

The lights should be visually inspected for general condition, proper operation, and correct installation at each annual and/or 100 hours inspection. In addition refer to section 1.10 of installation manual for detailed cleaning instructions.

Turn the lights on and do the following:

1. Put on polarized sunglasses or welder goggles to prevent eye damage when looking into the lights.
2. Examine the individual LEDs as per the diagram below. If two adjacent LEDs in any location do not work, the Aveo **RedBaron Combo HISL 1000** light shall be removed and sent to Aveo Engineering for replacement under the Aveo Warranty Program. *(There are no removable parts on this light)*

*Top LEDs*

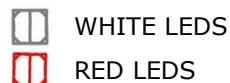

*Bottom LEDs*

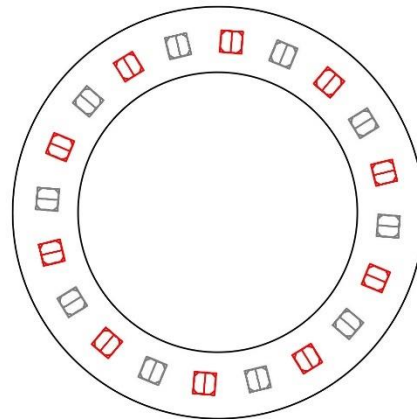
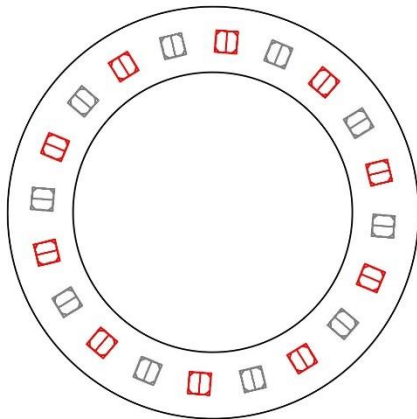
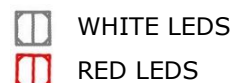

## 1.15 RoHS Compliance Statement

### Scope

This statement clarifies Aveo Engineering's compliance with European Union Directive 2015/863/EU on the restriction of the use of certain hazardous substances in electrical and electronic equipment ("RoHS") that took effect on June 4, 2015. The RoHS Directive restricts the sale of electronic equipment containing certain hazardous substances in the European Union including:

Cadmium(Cd): 0.01%  
Mercury: 0.1%  
Lead(Pb) : 0.1%  
Hexavalent chromium (Cr6+) : 0.1%  
Polybrominated biphenyls (PBB): 0.1 %;  
Polybrominated diphenyl ethers (PBDE): 0.1 %  
Bis(2-Ethylhexyl) phthalate (DEHP): 0.1% (added in 2015);  
Benzyl butyl phthalate (BBP): 0.1% (added in 2015);  
Dibutyl phthalate (DBP): 0.1% (added in 2015);  
Diisobutyl phthalate (DIBP): 0.1% (added in 2015)

### **Compliance**

Aveo Engineering certifies that all products sourced from manufacturing facilities comply with the environmental standards set forth by the Directive 2015/863/EU, recast amendment of RoHS Directive 2011/65/EU Article (4), and do not contain any of the above-mentioned, 10 hazardous substances above the specified limits. All products manufactured by Aveo Engineering are RoHS-compliant. With regards to RoHS-2 CE marking, product packaging is labeled attesting conformity if required.

### **References**

Directive 2015/863/EU of the European Parliament and of the Council on the restriction of the use of certain hazardous substances in electrical and electronic equipment.

## **1.16 EU REACH Regulation (EC) No. 1907/2006**

Aveo Engineering declares that no chemicals are produced and that none of the chemicals used during the production process or needed for the product maintenance or service, is listed on the current European Chemicals Agency's Candidate list of Substances of Very High Concern for Authorization.