



INSTALLATION MANUAL
Hercules Drop-In

AVE-H30TATSN-IM

TABLE OF CONTENTS

| | | |
|---------------|---|----------|
| PART 0 | DOCUMENT ADMINISTRATION..... | 3 |
| 0.1 | DOCUMENT APPROVAL..... | 3 |
| 0.2 | AMENDMENT RECORD PROCEDURE | 4 |
| 0.3 | AFFECTED PAGES PROCEDURE | 4 |
| PART 1 | INSTALLATION DATA..... | 5 |
| 1.1 | PRODUCT INFO | 5 |
| 1.2 | OPERATING INSTRUCTIONS..... | 5 |
| 1.3 | INSTALLATION SCHEMATIC / WIRING DIAGRAM | 5 |
| 1.4 | CONTROL & POWER INPUTS | 5 |
| 1.5 | TECHNICAL SPECIFICATION..... | 6 |
| 1.6 | TECHNICAL DRAWING | 7 |
| 1.7 | WIRING CHART..... | 8 |
| 1.8 | OPTIC SIMULATION | 9 |
| 1.9 | EQUIPMENT LIMITATION..... | 10 |
| 1.10 | CARE AND CLEANING OF LIGHTS..... | 10 |
| 1.11 | TESTING THE LIGHTS BEFORE INSTALLATION | 10 |
| 1.12 | CONTINUED AIRWORTHINESS INFORMATION..... | 11 |
| 1.13 | ROHS COMPLIANCE STATEMENT..... | 11 |
| 1.14 | EU REACH REGULATION (EC) No. 1907/2006 | 12 |

Part 0 Document Administration

0.1 Document Approval

This document has been established in accordance with an alternative procedure to DOA approved under EASA AP429.

This installation manual is applicable for following part numbers:

- **Hercules Drop-In Landing** - AVE-H30TATSNL-T0A Mod(1)
- **Hercules Drop-In Taxi** - AVE-H30TATSNT-T0A Mod(1)



Compiled by: _____ 09 Mar 2023

Petr Jaroš
Engineer, Aveo Engineering Group, s.r.o.



Approved by: _____ 09 Mar 2023

Georg Hartl
Head of DO, Aveo Engineering Group, s.r.o.

0.2 Amendment Record Procedure

The master copy of this document shall be kept electronically as a read only document under the control of Aveo Engineering Group, s.r.o. as Master Copy.

ALL amendments to this manual will initiate a raise of issue.

The original issue will be identified by "01", and subsequent issues will be numbered sequentially from 02 to 99 in Table 01 - **Issue No.** column.

ALL issues of this document will be approved by Head of DO.

| Issue No. | Details | Date of issue | Affected Pages |
|--|---------------|---------------|----------------|
| 01 | Initial Issue | 09 Mar 2023 | ALL |
| | | | |
| | | | |
| Table 01: Record of Document Amendments | | | |

0.3 Affected Pages Procedure

ALL pages affected by ANY raise of issue of this document will be listed in Table 01 - **Affected Pages** Column.

The reason(s) for **EACH** raise of issue and the description of respective change will be provided in Table 01 - **Details** Column.

Changes from the previous issue are shown as follows:

- a) new text is highlighted with yellow shading: **new**
- b) deleted text is shown with yellow shading and a strike through: ~~**deleted**~~

Part 1 Installation data

1.1 Product Info

Hercules Drop-In is a high powered PAR36 LED light use in GA and transport category aircraft. It has been designed to be lightweight and with a low power draw to meet the highest requirements of all certified aircraft.

- **Hercules Drop-In Landing** - AVE-H30TATSNL-T0A Mod(1)
- **Hercules Drop-In Taxi** - AVE-H30TATSNT-T0A Mod(1)

1.2 Operating Instructions

When installed on the aircraft, using the aircraft's power (14 or 28 volts), the light will be at its maximum intensity.

Operating Voltage range is +9...+36VDC.

1.3 Installation Schematic / Wiring Diagram

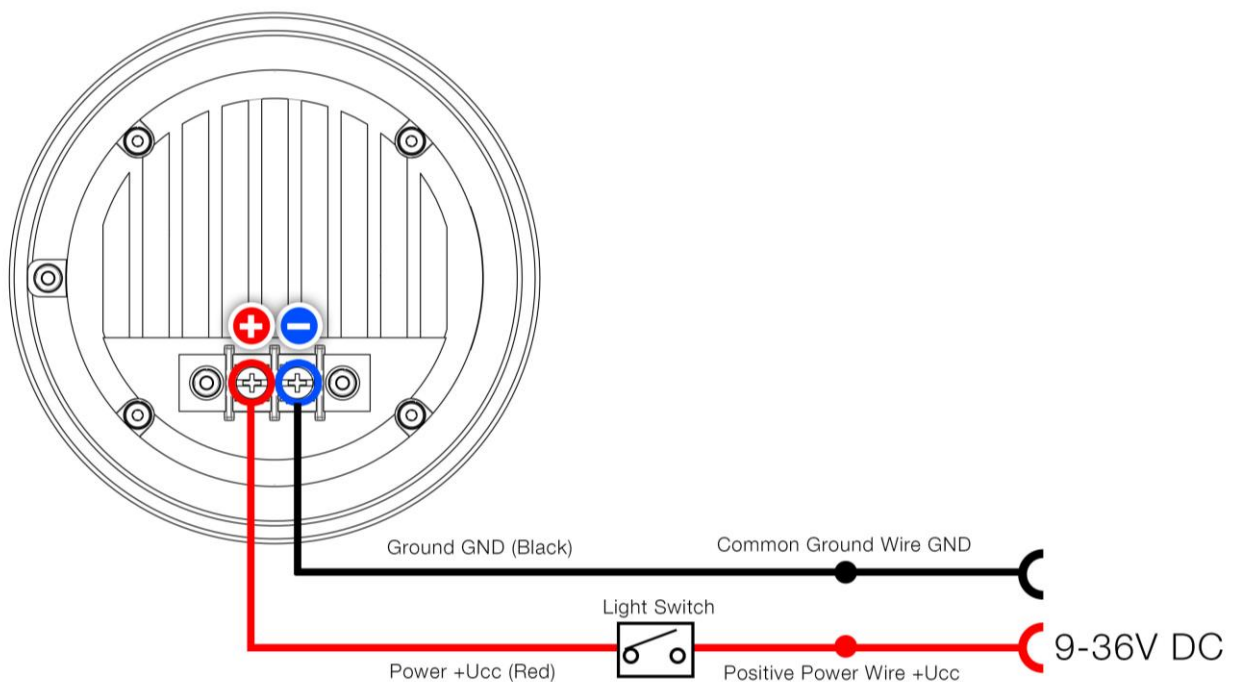

1.4 Control & Power Inputs

RED White LEDs Power
BLUE GND Common

1.5 Technical Specification

| | |
|-------------------------------|---|
| Light characteristics: | PAR36 replacement (Landing or Taxi Light) |
| Voltage range: | 9-36VDC |
| Voltage protection: | a. Transient voltage: 2 seconds +80VDC b. Under-voltage lockout: +9VDC, not more c. Over-voltage lockout: +36VDC, not less |
| Performance: | |
| Input current: | 2A@14VDC 1A@28VDC |
| Input power: | 28W@14VDC 28W@28VDC |
| Chromaticity: | Cool White |
| Ambient temperature: | -55°C...+85°C / -67°F...+185°F |
| Overheat protection: | Yes |
| Wiring: | See sections 1.3 and 1.4 |
| Weight: | 406 g / 0.895 lb |
| Useful life: | not less than 15.000 aircraft flight hours |

| Environment | Section | Category |
|--|---------|------------|
| Temperature / Altitude | 4 | F2 |
| Temperature Variation | 5 | A |
| Humidity | 6 | C |
| Operational Shock and Crash Safety | 7 | B |
| Vibration | 8 | R, curve W |
| | | U, curve G |
| Explosive Atmosphere | 9 | H |
| Waterproofness | 10 | R |
| Fluids Susceptibility | 11 | F |
| Sand and dust | 12 | D |
| Fungus | 13 | F |
| Salt Spray | 14 | T |
| Magnetics Effects | 15 | Z |
| Power Input | 16 | ZXX |
| Voltage Spike | 17 | A |
| Audio Freq. Conducted Susceptibility | 18 | Z |
| Induced Signal Susceptibility | 19 | ZCX |
| Radiated and Conducted Susceptibility | 20 | TT |
| Radiated and Conducted Emissions | 21 | L |
| Lightning Induced Transient Susceptibility | 22 | A2E2X |
| Icing | 24 | A |
| Electrostatic Discharge | 25 | A |

1.6 Technical Drawing

Hercules Drop-In Taxi - AVE-H30TATSNT-T0A Mod(1)

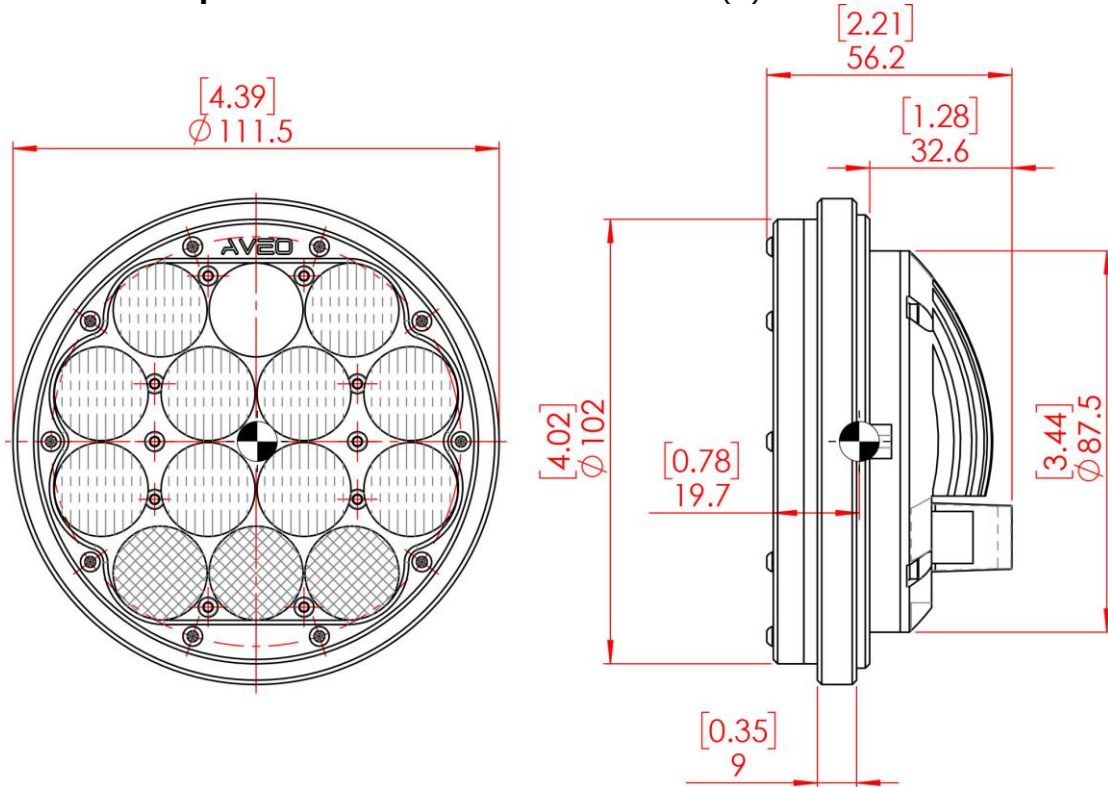

*dimensions in [inches] / mm

Hercules Drop-In Landing - AVE-H30TATSNTL-T0A Mod(1)

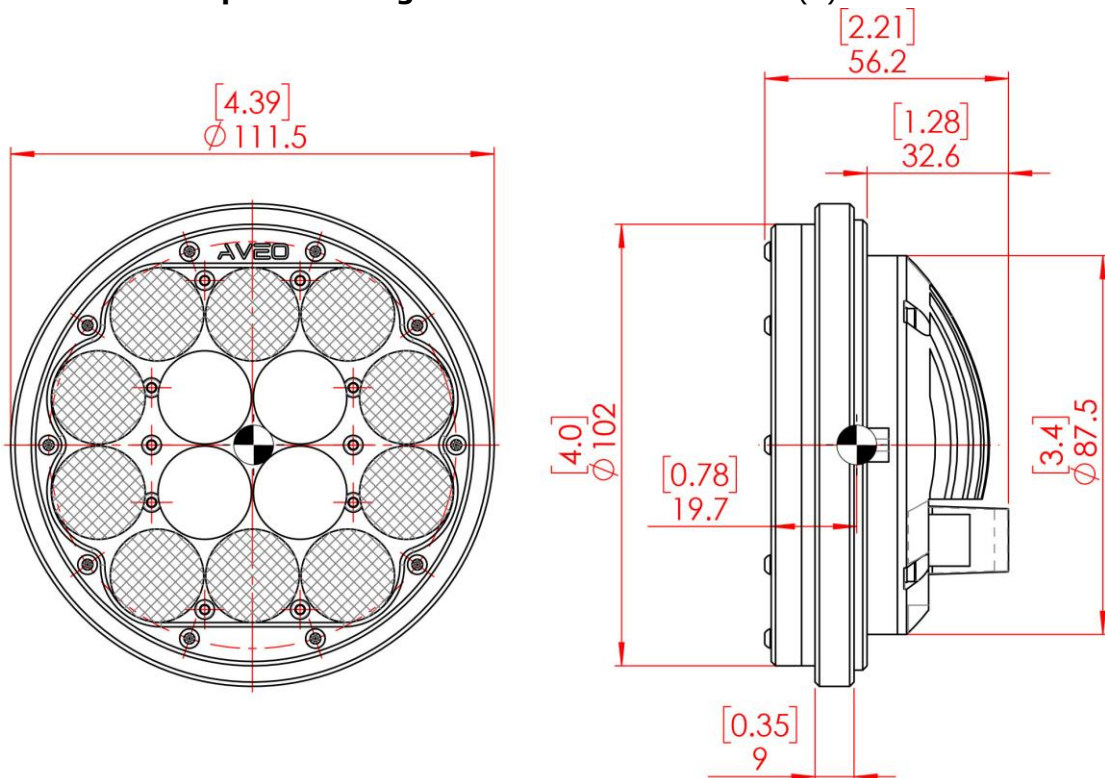

*dimensions in [inches] / mm

1.7 Wiring Chart

Use diagram below defining the wiring size depending on the current and the wire length. Make sure you add up the current for all connected lights. If current is not given, then divide the power by the voltage.

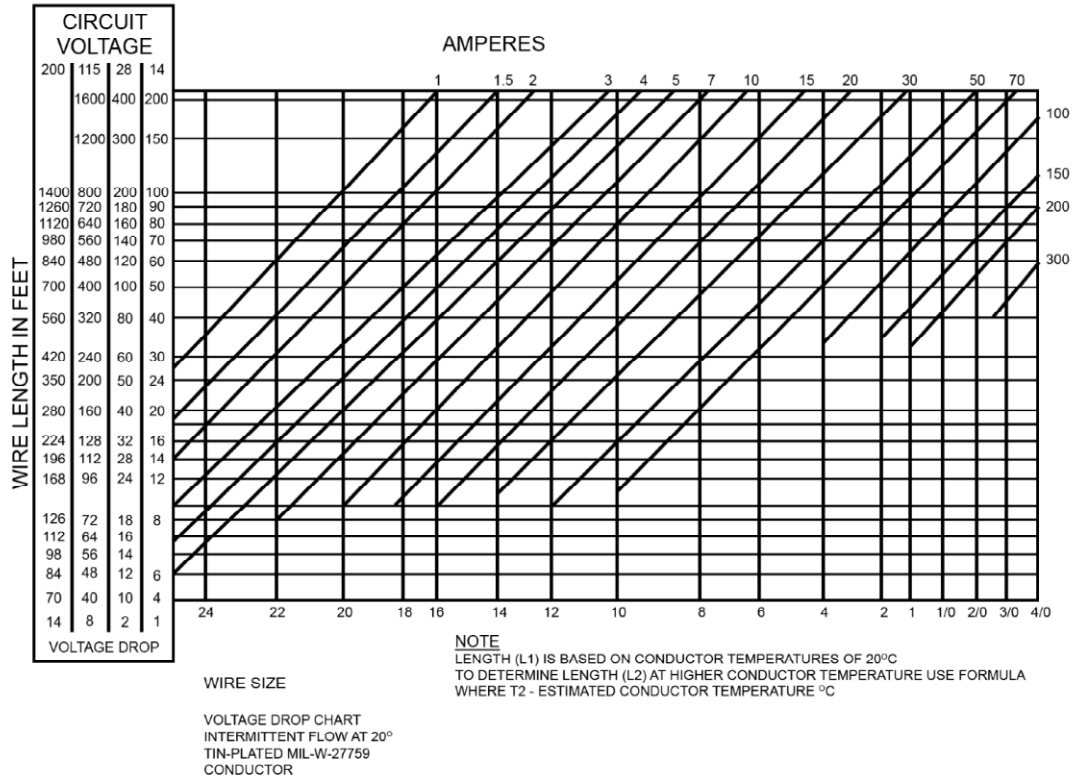

1.8 Optic Simulation

Hercules Drop-In Landing - AVE-H30TATSNL-T0A Mod(1)

8.6°
159000 cd

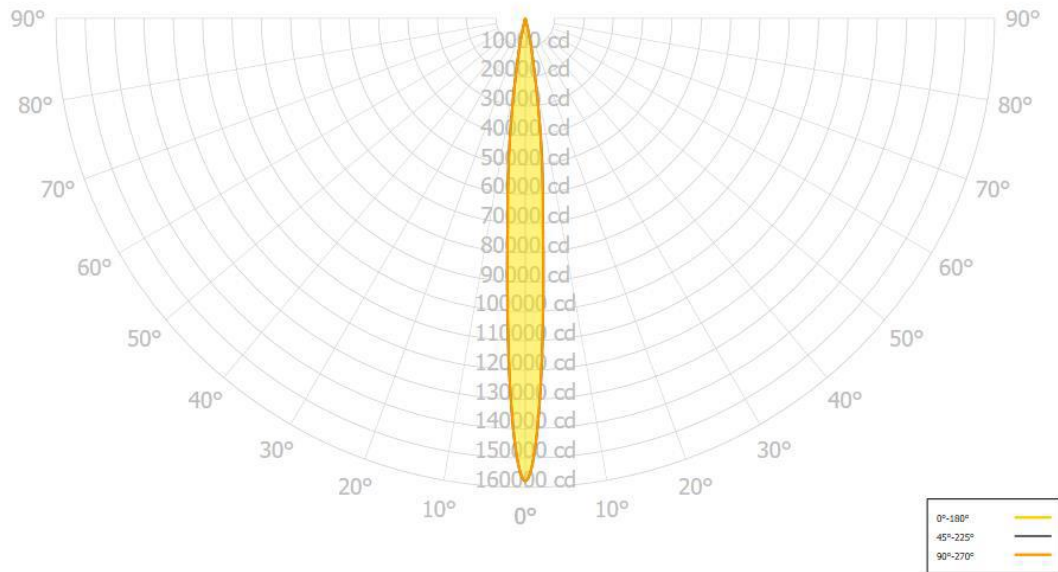

Hercules Drop-In Taxi - AVE-H30TATSNT-T0A Mod(1)

40°x 9°
67000 cd

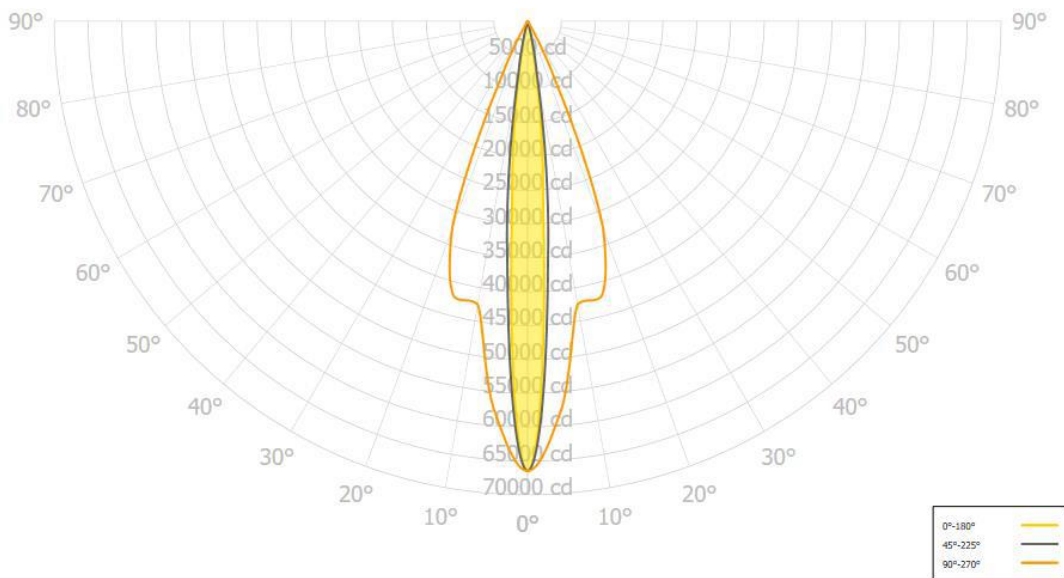

1.9 Equipment Limitation

Hercules Drop-In should only be powered by 9-36VDC

1.10 Care and Cleaning of Lights

Aveo Engineering Aviation Lights are factory polished and delivered as ready to install on the aircraft.

If the lights need a deeper cleaning, they should be polished with a quality lamb's wool sheet that is suitable also for deeper polishing. Under no circumstances should any petroleum based product be used to clean the lights.

1.11 Testing the Lights before Installation

All Aveo Aviation lights undergo rigorous testing prior to being released from our engineering manufacturing department. This testing involves a burn-in time as well as other function testing. No light is released for sale without undergoing this extensive operational testing.

When you receive the **Hercules Drop-In** light, and wish to test the function of the light prior to installation on your aircraft, please note the following:

1. Please review the written information that is enclosed in the packaging. Warranty information as well as a cautionary note about power supply removal is enclosed with each package.
2. Remove the light from the package. Note that there is a connector with 2 colors:

| | |
|------|--------------------|
| RED | - White LEDs Power |
| BLUE | - GND Common |
3. Testing of the function of the light can be done with a regular 14VDC or 28VDC power supply (not a battery charger). Connect the ground wire to blue pole and then connect the power wire to the red pole. The white light section should start lighting. Disconnect all wires. When installed on the aircraft, using the aircraft's power (14VDC or 28VDC), the light will be at its maximum intensity.

After testing, the light can be installed on the aircraft.

IMPORTANT NOTES:

Under no circumstances should any power supply other than a 9-36VDC, or a 14 or 28 volt battery be used to test the light. Do not use: Battery chargers, battery back-up power devices, or other bench avionics testing methods to test the aviation light. The light is functional between 9-36 volts. Use of a battery charger or other power unit to test the light will void the warranty and may damage the light.

If you have any questions about the installation of the lights, please refer to our web site: www.aveoengineering.com

1.12 Continued Airworthiness Information

Circuit/Wiring Protection

Each Hercules series light features a **Negative Temperature Coefficient** (NTC) circuit that limits internal temperatures by attenuating operating current (with a corresponding reduction of brightness) when internal temperatures reach a certain threshold. This proprietary circuitry serves to protect the light itself, and associated aircraft wiring, against a thermal runaway condition.

Periodic Inspection Procedure for Hercules Drop-In

The **Hercules Drop-In** light should always be checked for proper operation during preflight. This procedural information is already provided in all general aviation aircraft flight manuals.

The lights should be visually inspected for general condition, proper operation, and correct installation at each annual and/or 100 hours inspection. In addition refer to section 1.10 of installation manual for detailed cleaning instructions.

1.13 RoHS Compliance Statement

Scope

This statement clarifies Aveo Engineering's compliance with European Union Directive 2015/863/EU on the restriction of the use of certain hazardous substances in electrical and electronic equipment ("RoHS") that took effect on June 4, 2015. The RoHS Directive restricts the sale of electronic equipment containing certain hazardous substances in the European Union including:

Cadmium(Cd): 0.01%
 Mercury: 0.1%
 Lead(Pb) : 0.1%
 Hexavalent chromium (Cr6+) : 0.1%
 Polybrominated biphenyls (PBB): 0.1 %;
 Polybrominated diphenyl ethers (PBDE): 0.1 %
 Bis(2-Ethylhexyl) phthalate (DEHP): 0.1% (added in 2015);
 Benzyl butyl phthalate (BBP): 0.1% (added in 2015);
 Dibutyl phthalate (DBP): 0.1% (added in 2015);
 Diisobutyl phthalate (DIBP): 0.1% (added in 2015)

Compliance

Aveo Engineering certifies that all products sourced from manufacturing facilities comply with the environmental standards set forth by the Directive 2015/863/EU, recast amendment of RoHS Directive 2011/65/EU Article (4), and do not contain any of the above-mentioned, 10 hazardous substances above the specified limits. All products manufactured by Aveo Engineering are RoHS-compliant. With regards to RoHS-2 CE marking, product packaging is labeled attesting conformity if required.

References

Directive 2015/863/EU of the European Parliament and of the Council on the restriction of the use of certain hazardous substances in electrical and electronic equipment.

1.14 EU REACH Regulation (EC) No. 1907/2006

Aveo Engineering declares that no chemicals are produced and that none of the chemicals used during the production process or needed for the product maintenance or service, is listed on the current European Chemicals Agency's Candidate list of Substances of Very High Concern for Authorization.