



Installation Instruction BEECHCRAFT KING AIR 200, 300 & 350

Part 0 Manual Administration

0.1 Table of Contents

PART 0	MANUAL ADMINISTRATION	2
0.1	TABLE OF CONTENTS	2
0.2	DOCUMENT APPROVAL	3
0.3	AMENDMENT RECORD PROCEDURE	3
0.4	EFFECTED PAGES PROCEDURE	4
0.5	DISTRIBUTION LIST	4
PART 1	INSTALLATION INSTRUCTION	5
1.1	GENERAL	5
1.2	CONTINUED AIRWORTHINESS	5
1.3	DESCRIPTION	5
1.4	WING POSITION LIGHTS INSTALLATION	6
1.5	REAR POSITION LIGHT INSTALLATION	9
1.6	ANTI-COLLISION LIGHTS INSTALLATION	11
1.7	RECOGNITION LIGHTS INSTALLATION - WINGTIP	13
1.8	TAXI AND LANDING LIGHTS INSTALLATION – NOSE GEAR	15
PART 2	COMPLIANCE DEMONSTRATION	17

0.2 Document approval

This document has been established in accordance with an alternative procedure to DOA approved under EASA AP429.

This installation Instruction is applicable for the Beechcraft models B200, B200C, B200GT, B200CGT, B300 and B300C.

Compiled by: _____ 5. – Apr. - 2018
Petr Jaros
Engineer, Aveo Engineering Group, s.r.o.

Approved by: _____ 5. – Apr. - 2018
Georg Hartl
Head of DO, Aveo Engineering Group, s.r.o.

0.3 Amendment Record procedure

The master copy of this document shall be kept electronically as a read only document under the control of Aveo Engineering Group, s.r.o. as Master Copy.

ALL amendments to this manual will initiate a raise of Issue

ALL raises of issue will be given a sequential Alphabetic Issue Ident sequentially from 01 to 99 in Table 01 - **Issue No:** Column– Initial Issue of Document will be **“01”**

ALL Issues of this document will be approved by Head of DO

Issue No.	Details	Date	Effected Pages
01	Initial Issue	15.Dec.2016	ALL
02	Add statement Add removal of high-voltage unit Correct typo		8 9-10 14
03	Landing and TAXI Light P/N changed	20. – Mar. - 2018	16
04	Precise statement Add step for corrosion protection	5.Apr.2018	5 8

Table 01: Document Amendment Record Table

0.4 Effected Pages Procedure

ALL pages affected by ANY raise of issue of this manual will be listed in Table 01 - *Effected Pages* Column.

The reason(s) for ALL raise of issue and description of change due to raise of issue will be provided for ALL raises of issue in Table 01 - *Details* Column.

Changes from the previous issue are highlighted by **YELLOW HIGHLIGHTING** over new content. AND **YELLOW HIGHLIGHTING** AND CROSSING OUT of deleted content.

Example (**CROSSING OUT**)

0.5 Distribution List

As stated in 0.3 above; the master copy of this document shall be kept electronically as a read only document under the control of Aveo Engineering Group, s.r.o. as Master Copy.

All holders of copies of this Document will be recorded by listing in Table 02 – Distribution List.

Copy holders listed will be issued a copy of this document with sequential copy number as shown in Table 02 – Distribution List

Copy No.	Holder
MASTER	Aveo Engineering Group, s.r.o.
Table 02: Distribution List	

Part 1 Installation Instruction

1.1 General

This installation is to be performed in accordance to common practice as described in FAR AC 43.13-2B Chapter 4 and in FAR AC 43.13 1B Chapter 11 Section 15 (Bonding) as published by FAA.

The installer is responsible to follow the installation instructions in the latest revision of:

- FAR AC 43.13-2B Chapter 4
- FAR AC 43.13 1B Chapter 11 Section 15
- AVE-WPS-64G-IM
- AVE-POSW-54G-IM
- AVE-RBXP-001-IM
- AVE-N09PANSNT-OHA-IM
- AVE-H30-001-IM

All drawings applicable for this change are listed in the Drawing List:

- AVE-MOD-008-DL, issue 02

The following appliances carry an ETSO authorization:

- AVE-WPSR-64G & AVE-WPSG-64G – ETSOA 210.10053936
- AVE-RBXPR-001 – ETSOA 210.10055069
- AVE-POSW-54G – ETSOA.210.10053449

The change is to be performed using the document AVE-MOD-008-MCS in the latest issue.

The aircraft modified according to this instruction may not be released back to service without the EASA design approval certificate being provided.

1.2 Continued Airworthiness

The aircraft manuals remain fully valid. The inspection intervals and the procedures of the aircraft override the general statements in the component manuals as listed under §1.1.

For inspection of the new lights themselves follow the procedure of the Aveo Installation Manuals referenced above.

1.3 Description

This modification is the replacement of position lights (type I, II & III), anti-collision lights, strobe lights, taxi lights and the landing lights by LED type lights.

In general the lights are direct replacements and do not require any structural change on the A/C side. **Only exemption may be additional attachment holes and installation of anchor nuts in the secondary bracket of the wingtip light installation.** The changes in wiring are very minor and are to be done according to referenced standard practice.

1.4 Wing Position Lights Installation

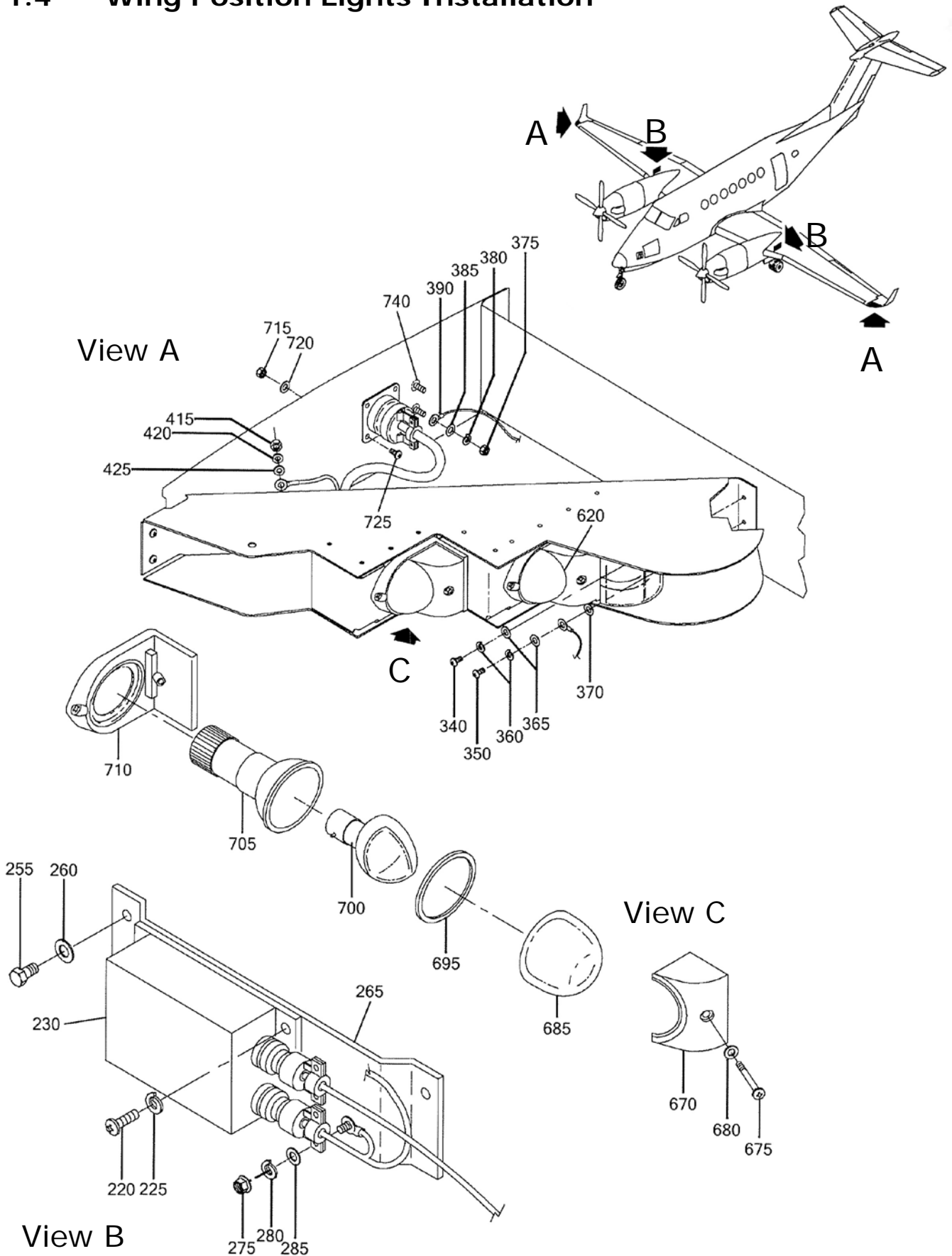

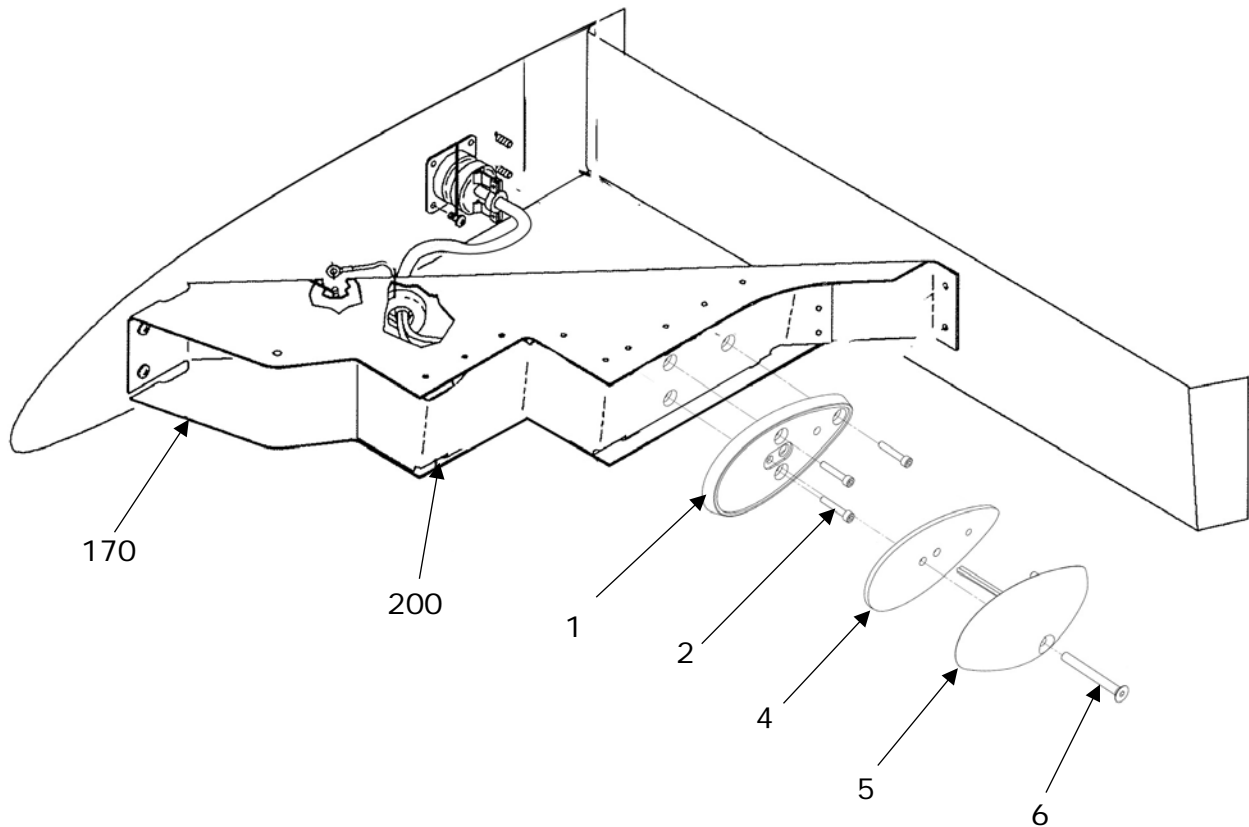

Figure and Index Number	Part Number	Description	Parts Avail.	QTY. Per assy.
1	AVS-P000100175-A6A	Ultra Galactica Adapter		2
2	AVS-SCC05013LHS-C0A	Screw#6-32 x1/2" LPSHS		6
3	AVS-HLC0531RHS-U0A	Nylon-Insert Locknut		3
4	AVS-P001290550-A1A	Gasket		2
5	AVE-WPSR-64G	Ultra Galactica Embedded Red		1
	AVE-WPSG-64G	Ultra Galactica Embedded Green		1
6	AVS-SCM05045LHS-D0A	Mounting Screw M5 x 45		2

	Original parts			
170	130-170033-19	Bracket-LH		1
(175)	130-170033-35	Bracket-LH		1
(180)	130-170033-20	Bracket-RH		1
(185)	130-170033-36	Bracket-RH		1
(200)	130-170033-23	Bracket-LH		1
(205)	130-170033-24	Bracket-RH		1
220	MS35206-245	Screw		8
225	NAS1149F0332P	Washer		8
230	100-384118-19	Power supply-wingtip		2
255	130909B12	Bolt		8
260	NAS1149F0332P	Washer		8
265	101-361163-5	Bracket – wing tip power supply		2
275	130909N29	Nut		2

280	MS35338-43	Washer lock		2
285	NAS1149F0332P	Washer		2
340	MS35207-263	Screw		3
	NAS1096-3-8	Screw		3
350	MS35207-264	Screw		1
	NAS1096-3-9	Screw		1
360	MS35338-43	Washer lock		4
365	NAS1149F0332P	Washer		4
370	NAS1149D0316H	Washer		1
375	130909N29	Nut		1
380	MS35338-43	Washer lock		1
385	NAS1149F0332P	Washer		1
390	MS205832BB12	Jumper assy bonding		1
415	130909N29	Nut		2
420	MS35338-43	Washer lock		2
425	NAS1149F0332P	Washer		2
620	130-381000-1	Light assy – LH, position and strobe		1
625	130-381000-2	Light assy – RH, position and strobe		1
670	A6177	Retainer-Lens		1
675	NAS388-6-16	Screw		1
680	MS35336-9	Washer lock		1
685	A1280-2	Lens – LH red		1
690	A1280-3	Lens – RH green		1
700	A7512-24	Lamp – navigation light		1
705	A1825	Lamp holder assembly		1
710	A1811	Base – navigation light		1
715	MS21042L04	Nut		1
720	NAS1149FN416P	Washer		4
725	MS35206-216	Screw		4
740	131270-3	Stud - Ground		2

NOTES

1. Remove both position and the strobe lights (View C) in accordance to the aircraft maintenance manual.
2. Disconnect the wire bundle from the position and the strobe light
3. Inspect the installation area for corrosion and correct according to AMM if required
4. Install item 1 to 5 as described. Holes on bracket items 170 to 205 are to be drilled on installation and anchor nuts installed as required. Items 170 to 205 may be trimmed as necessary. After trimming remove sharp edges and apply primer.
5. **Apply corrosion protection to all unused holes as per AMM.**
6. Wiring for forward position light is to be capped and stowed.
7. Splice the new light's wires into the bundle according to the referenced installation manuals and the common practice FAR AC 43.13-2B Chapter 4
8. Remove strobe box (View B) according to the aircraft maintenance manual and remove connectors on both sides. Splice the wires in accordance to common practice FAR AC 43.13-2B Chapter 4as follows:
 - a. 28VDC to ANODE
 - b. SYNC to TRIGGER
 - c. GND to CATHODE

1.5 Rear Position Light Installation

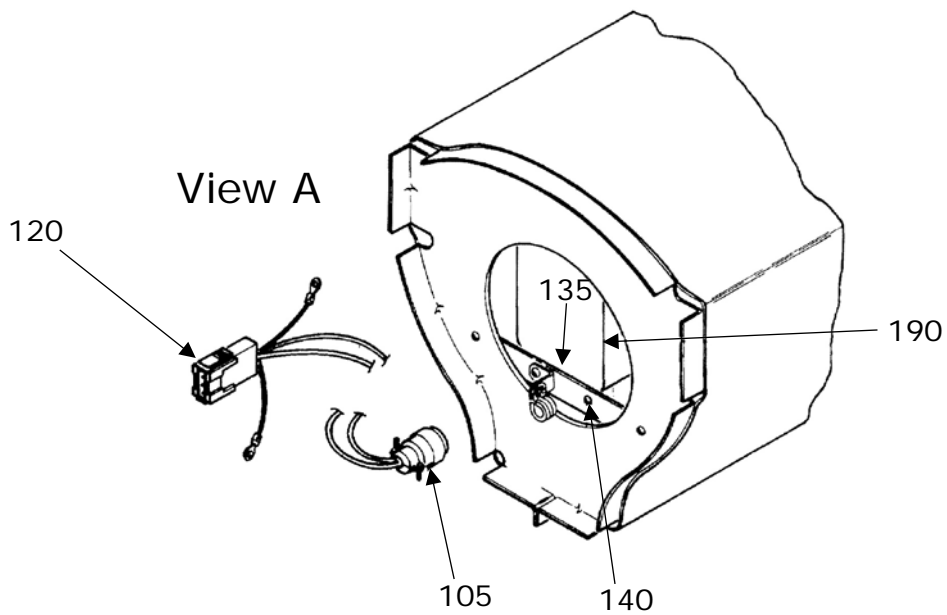
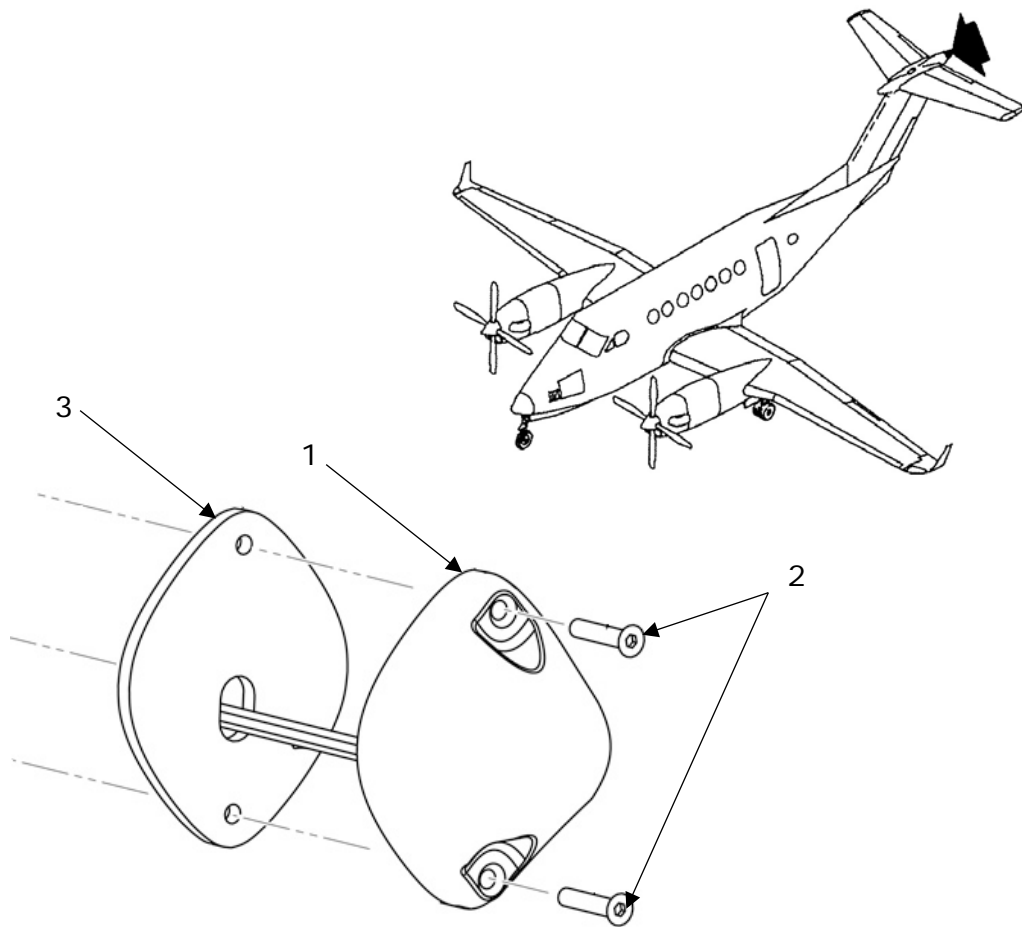

Figure and Index Number	Part Number	Description	Parts Avail.	QTY. Per assy.
1	AVE-POSW-54G	PosiStrobe CP		1
2	MS-24671-4	Screw #4-40 x 5/8" FHSCS		2
3	AVS- P000103402-A1A	Gasket		1

	View A			
105	MS3456L10SL3S	Connector		1
120	207573-1	Housing Pin		1
135	101-361159-9	Strap		1
140	MS35206-245	Screw		5
190	100-384118-9	Power Supply – Strobe Light		1
	100-384118-21			

NOTES

1. Remove position light in accordance to the aircraft maintenance manual.
2. Disconnect the wire bundle from the position light
3. Inspect the installation area for corrosion and correct according to AMM if required
4. Splice the new light's wires into the bundle according to the referenced installation manuals and the common practice FAR AC 43.13-2B Chapter 4
5. Install item 1 to 3 as described.
6. Remove strobe box (View A) according to the aircraft maintenance manual and remove connectors on both sides. Splice the wires in accordance to common practice FAR AC 43.13-2B Chapter 4as follows:
 - a. 28VDC to ANODE
 - b. SYNC to TRIGGER
 - c. GND to CATHODE

1.6 Anti-collision Lights Installation

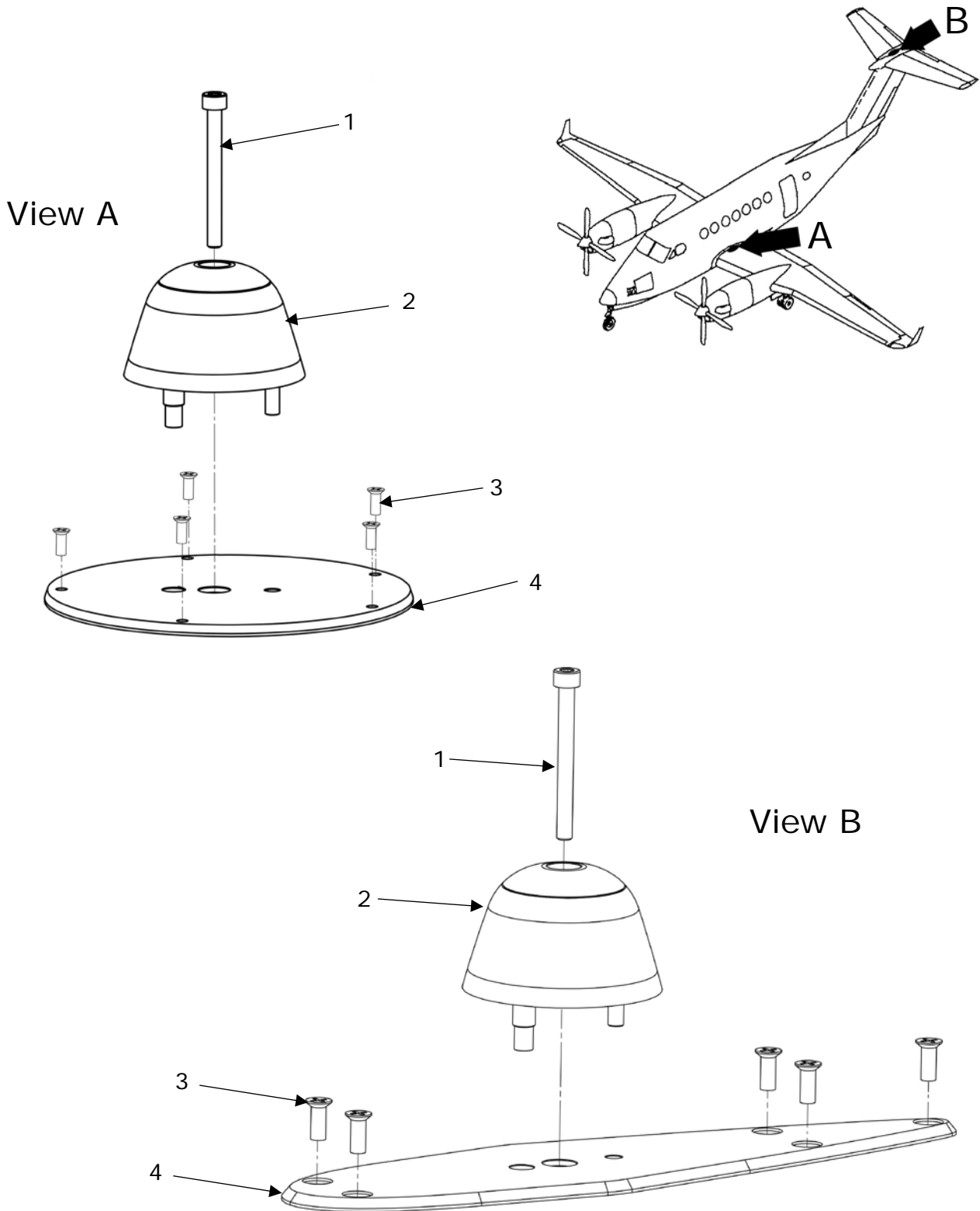

Figure and Index Number	Part Number	Description	Parts Avail.	QTY. Per assy.
A		BOTTOM ANTI-COLLISION LIGHT INSTALLATION		
1	AVS-P000102111-A3A	Hex Socket Metric Screw Assy		1
2	AVE-RBXPR-001	RedBaron XP Galactica		1
3	MS24693-S28	Original Fasteners		5
4	AVS- P000600093-A60	RedBaron XP Light Replacement Adapter 2		1
B		UPPER ANTI-COLLISION LIGHT INSTALLATION		
1	AVS-P000102111-A3A	Hex Socket Metric Screw Assy		1
2	AVE-RBXPR-001	RedBaron XP Galactica		1
3	MS24694-S50	Original Fasteners		4
4	AVS- P000600092-A60	RedBaron XP Light Replacement Adapter 1		1

NOTES

1. Remove A523 lower flashing beacon in accordance to the aircraft maintenance manual.
2. Disconnect the wire bundle from the flashing beacon
3. Inspect the installation area for corrosion and correct according to AMM if required
4. Splice the new light's wires into the bundle according to the referenced installation manuals and the common practice FAR AC 43.13-2B Chapter 4
5. Install item A1 to 5 as described in view A. Drill hole to substructure for anti-rotation pin as required.
6. Remove A524 upper flashing beacon in accordance to the aircraft maintenance manual.
7. Disconnect the wire bundle from the flashing beacon
8. Splice the new light's wires into the bundle according to the referenced installation manuals and the common practice FAR AC 43.13-2B Chapter 4
9. Install item B1 to 5 as described in view B. Drill hole to substructure for anti-rotation pin as required.

1.7 Recognition Lights Installation - Wingtip

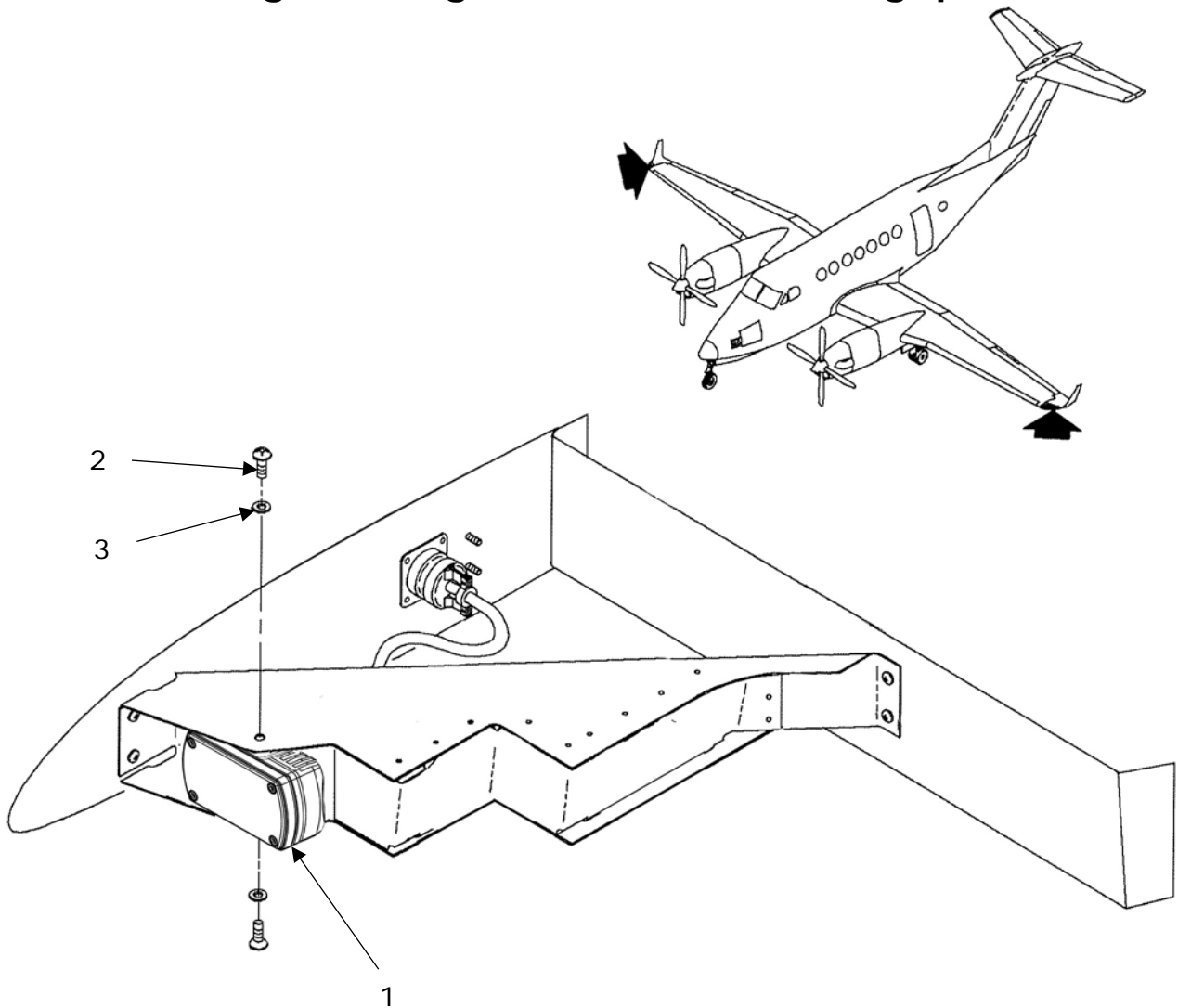

Figure and Index Number	Part Number	Description	Parts Avail.	QTY. Per assy.
1	AVE-N09PANSNT-0HA	Nubion		2
2	MS-51957-43	Screw #8-32 x 3/8" PHPMS		4
3	AVS-WSRU0834IFN-U0A	#8 Self-Retaining Washer		4

NOTES

1. Remove recognition light in accordance to the aircraft maintenance manual.
2. Disconnect the wire bundle from the recognition light
3. Inspect the installation area for corrosion and correct according to AMM if required
4. Splice the new light's wires into the bundle according to the referenced installation manuals and the common practice FAR AC 43.13-2B Chapter 4
5. Install item 1 to 3 as described.

1.8 Taxi and Landing Lights Installation – Nose Gear

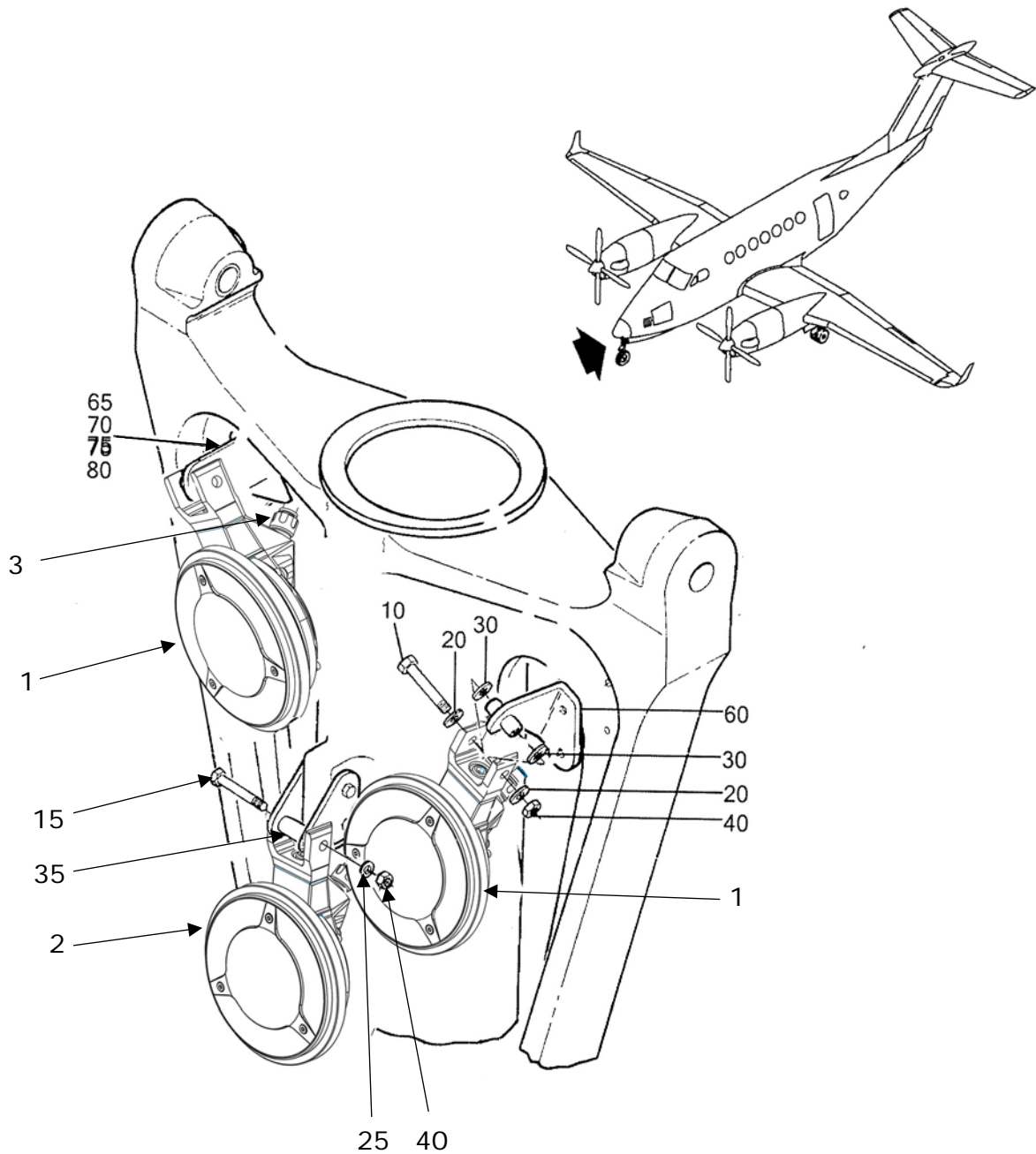

Figure and Index Number	Part Number	Description	Parts Avail.	QTY. Per Assy.
1	AVE-H30-W-112	Hercules LLP Landing		2
2	AVE-H30-W-111	Hercules LLP Taxi		1
-----	-----	-----	-----	-----
	Original parts			
10	130909B46	Bolt		2
15	130909B44	Bolt		1
20	NAS1149F0432P	Washer		4
25	NAS1149F0463P	Washer		1
30	MS35333-40	Washer		4
35	NAS43DD4-48	Spacer		1
40	130909N32	Nut		3
60	90-360010-1	Bracket assy-LH		1
60	90-360010-17	Bracket assy-LH		1
		For spares order: 90-360042-0001		
60	90-360042-0001	Bracket assy-LH		1
		Spares replacement for 90-360010-17		
65	90-360010-2	Bracket assy-RH		1
65	90-360010-18	Bracket assy-RH		1
		For spares order: 90-360042-0002		
65	90-360042-0002	Bracket assy-RH		1
		Spares Replacement for 90-360010-18		
70	130909B19	Bolt		4
75	NAS1149F0332P	Washer		8
80	130909N29	Nut		4

NOTES

1. Remove landing and taxi light in accordance to the aircraft maintenance manual.
2. Disconnect the wire bundle from the landing and taxi lights.
3. Inspect the installation area for corrosion and correct according to AMM if required
4. Install connector item 3 in accordance with referenced installation manual
5. Install item 1 and 2 using the original hardware as described and in accordance to the aircraft maintenance manual.

Part 2 Compliance demonstration

This document is in relation to the certification program AVE-MOD-007-PFC.
The compliance is demonstrated for the following certification specification:

Requirements	MoC	Statement of Compliance
CS 23.609 Protection of structure	MoC 0	(a) All parts installed are verified to be suitable. The installation instruction requests the aircraft structure to be inspected for probable corrosion before installing the new lights. (b) Not applicable
CS 23.1301 Function and installation	MoC 0	(a) All navigation and anti-collision lights are ETSO certified. All landing lights are qualified according to RTCA DO160 as per AVE-H30-001-CCL. (b) Only one optional switch may be installed an label is defined herein. (c) All equipment is installed within their limits.
CS 23.1529 Instructions for Continued Airworthiness	MoC 0	The modification does not require any changes to the aircraft maintenance procedure which is clearly stated in §1.1 General.