



INSTALLATION MANUAL

Maximus 64 28VDC

AVE-MPDC-IM

© 2021 Aveo Engineering Group, s.r.o. All rights reserved. The information contained within this document must not be disclosed, copied or reproduced in whole or in part without prior written permission from Aveo Engineering Group, s.r.o.

TABLE OF CONTENTS

PART 0 DOCUMENT ADMINISTRATION	3
0.1 DOCUMENT APPROVAL.....	3
0.2 AMENDMENT RECORD PROCEDURE	4
0.3 EFFECTED PAGES PROCEDURE.....	4
PART 1 INSTALLATION DATA	5
1.1 MAXIMUS™ 64 28VDC	5
1.2 OPERATING INSTRUCTIONS.....	5
1.3 INSTALLATION SCHEMATIC / WIRING DIAGRAM	5
1.4 CONTROL & POWER INPUTS	6
1.5 TECHNICAL SPECIFICATION.....	6
1.6 TECHNICAL DRAWING	7
1.7 WIRING CHART.....	7
1.8 OPTIC SIMULATION	8
1.9 EQUIPMENT LIMITATION	8
1.10 CARE AND CLEANING OF LIGHTS.....	8
1.11 TESTING THE LIGHTS BEFORE INSTALLATION	8
1.12 NOTES ON INSTALLATION	9
1.13 CONTINUED AIRWORTHINESS INFORMATION.....	9
1.14 ROHS COMPLIANCE STATEMENT.....	10

Part 0 Document Administration

0.1 Document Approval

This document has been established in accordance with an alternative procedure to DOA approved under EASA AP429.

This installation manual is applicable for following part numbers:

- **Maximus 64 28VDC** **AVE-MP18LW-TD2**

Compiled by: _____ 11 Mar 2021
Petr Jaros
Engineer, Aveo Design Group, s.r.o.

Approved by: _____ 11 Mar 2021
Georg Hartl
Head of DO, Aveo Engineering Group, s.r.o.

0.2 Amendment Record Procedure

The master copy of this document shall be kept electronically as a read only document under the control of Aveo Engineering Group, s.r.o. as Master Copy.

ALL amendments to this manual will initiate a raise of issue.

The original issue will be identified by “**01**”, and subsequent issues will be numbered sequentially from 02 to 99 in Table 01 - **Issue No.** column.

ALL issues of this document will be approved by Head of DO.

Issue No.	Details	Date of issue	Effected Pages
01	Initial Issue	06 May 2020	ALL
02	Specification change	11 Mar 2021	6

Table 01: Record of Document Amendments

0.3 Effected Pages Procedure

ALL pages affected by ANY raise of issue of this manual will be listed in Table 01 - **Effected Pages** Column.

The reason(s) for **EACH** raise of issue and the description of respective change will be provided in Table 01 - **Details** Column.

Changes from the previous issue are shown as follows:

- a) new text is highlighted with yellow shading: **new**
- b) deleted text is shown with yellow shading and a strike through: ~~**deleted**~~

Part 1 Installation data

1.1 Maximus™ 64 28VDC

Maximus™ 64 28VDC is a high powered LED light use in GA and transport category aircraft. It has been designed to be lightweight and with a low power draw to meet the highest requirements of all certified aircraft.

- **Maximus 64 28VDC** - AVE-MP18LW-TD2

1.2 Operating Instructions

When installed on the aircraft, using the aircraft's power (28 volts), the light will be at its maximum intensity.

Operating Voltage range is +18..+36VDC.

1.3 Installation Schematic / Wiring Diagram

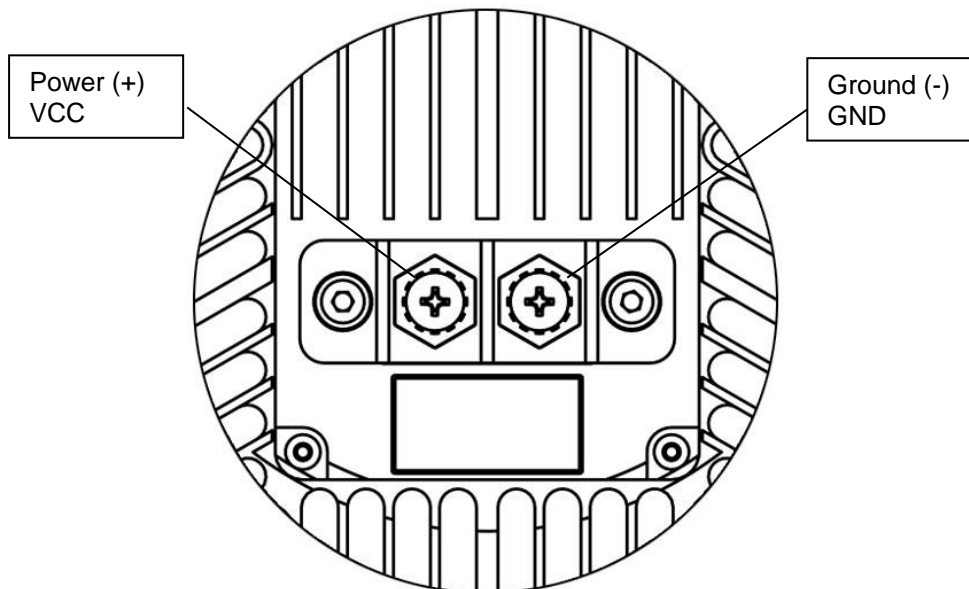

Recommended wire AWG size: **16**

1.4 Control & Power Inputs

BLACK Ground
RED Power

1.5 Technical Specification

Light characteristics: Landing Light / PAR64 replacement
Voltage range: 18-36 VDC
Voltage protection: a. Transient voltage: 2 second +40VDC
b. Over-voltage lockout: +30VDC, not less.
LED quantity: 18 pcs
Performance: Input current: **5.9A** @ 28VDC (rms) max
Input power: **165W** (typ)
Chromaticity: Cool White
Viewing Angle: 6°
Low temp. slope start: -55°C / -67°F
Ambient temperature: -55°C...+85°C / -67°F...+185°F
Overheat protection: Yes
Wiring: N/A, Terminal Block – 2 contacts
Weight: 1.291 kg / 2.846 lb
Useful life: not less than 30.000 aircraft flight hours.

Device RTCA/DO160 qualified:

- chapter 4, Temperature - Altitude, Category F2
- chapter 5, Temperature Variation, Category A
- chapter 6, Humidity, Category B
- chapter 7, Operational Shocks and Crash Safety, Category A
- chapter 8, Vibration, Category U, curves G
- chapter 9, Explosion proofness, Category H
- chapter 10, Waterproofness, Category S
- chapter 11, Fluids Susceptibility, Category F
- chapter 12, Sand and Dust, Category S
- chapter 13, Fungus resistance, Category F
- chapter 14, Salt spray, Category T
- chapter 15, Magnetic effects, Category Z
- chapter 16, Power Input, Category BX
- chapter 17, Voltage Spike, Category B
- chapter 18, Audio Frequency Conducted Susceptibility, Category B
- chapter 19, Induced Signal Susceptibility, Category AC
- chapter 20, Radio Frequency Susceptibility, Category TT
- chapter 21, Emission of Radio Frequency Energy, Category H
- chapter 22, Lightning induced transient susceptibility test, Category A2E2X
- chapter 24, Icing, Category A
- chapter 25, Electrostatic Discharge (ESD), Category A

1.6 Technical Drawing

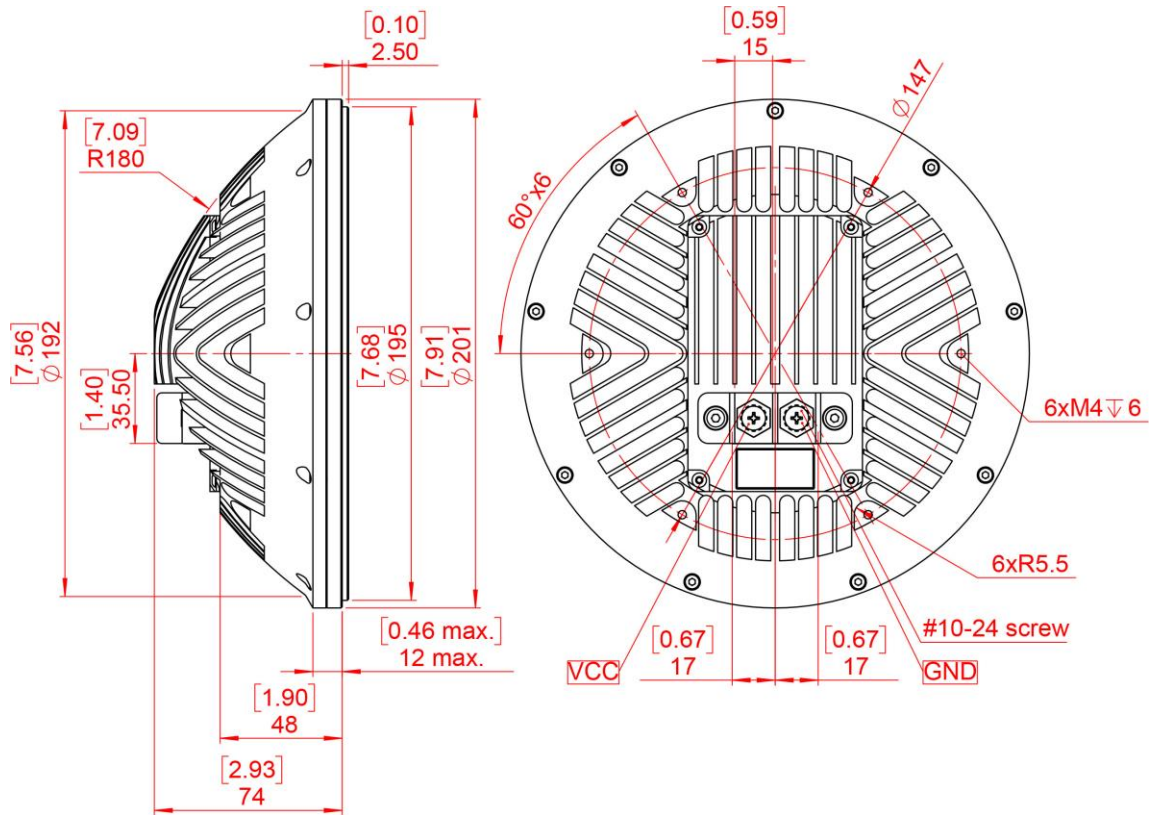

1.7 Wiring Chart

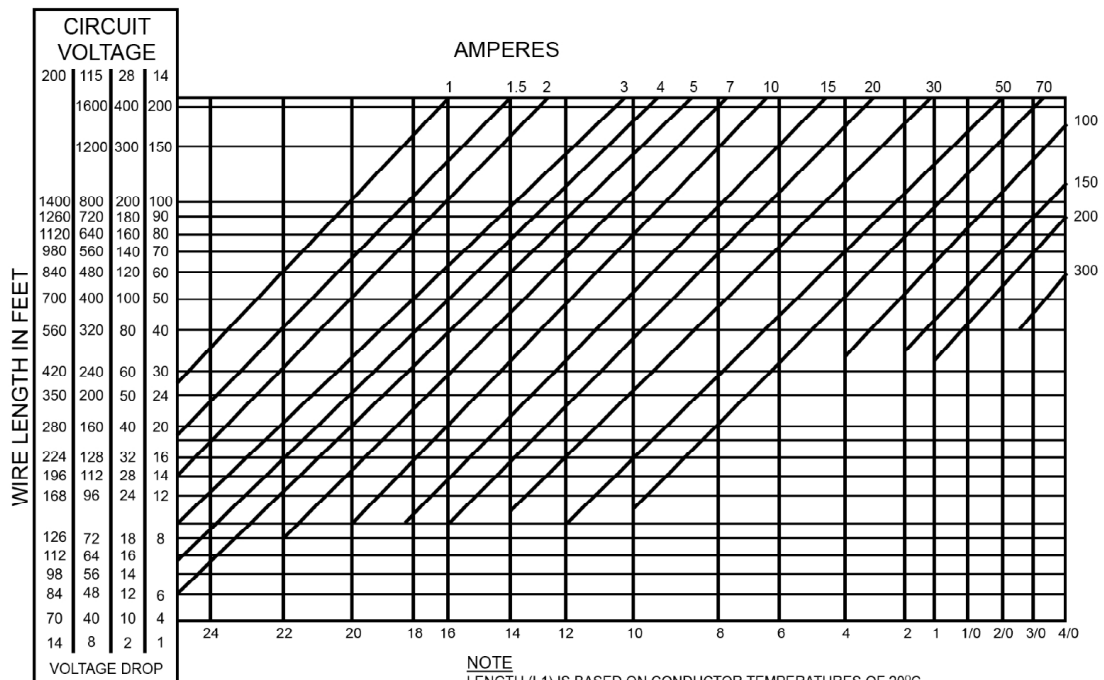

WIRE SIZE

VOLTAGE DROP CHART
INTERMITTENT FLOW AT 20°
TIN-PLATED MIL-W-27759
CONDUCTOR

NOTE
LENGTH (L1) IS BASED ON CONDUCTOR TEMPERATURES OF 20°C
TO DETERMINE LENGTH (L2) AT HIGHER CONDUCTOR TEMPERATURE USE FORMULA
WHERE T2 - ESTIMATED CONDUCTOR TEMPERATURE °C

1.8 Optic Simulation

6° at 50%: 1.040.000 Cd

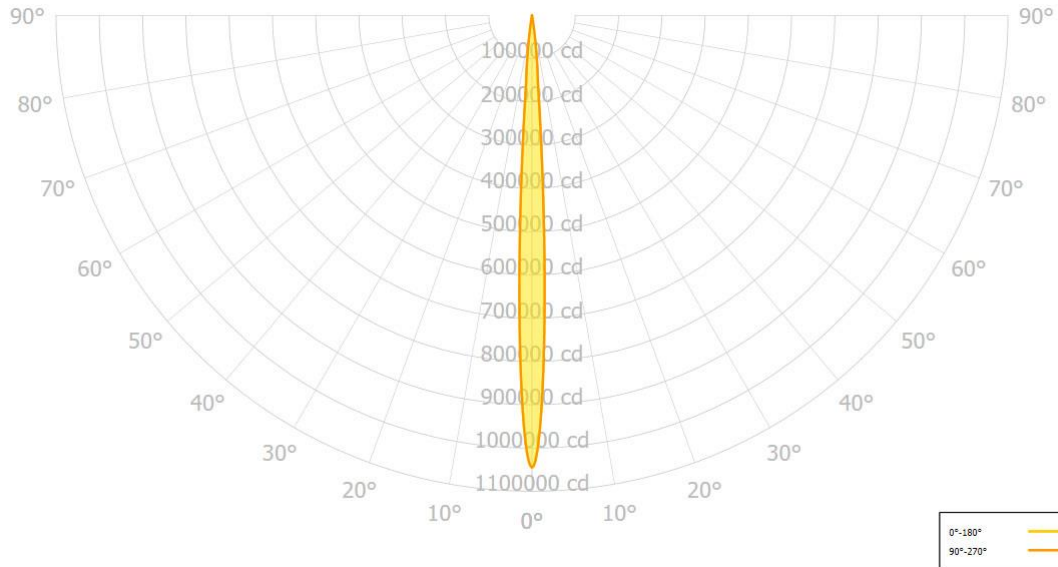

1.9 Equipment Limitation

Maximus 64 28VDC should only be powered by 18-36VDC.

1.10 Care and Cleaning of Lights

Aveo Engineering Aviation Lights are factory polished and delivered as ready to install on the aircraft.

If the lights need a deeper cleaning, they should be polished with a quality lamb's wool sheet that is suitable also for deeper polishing. Under no circumstances should any petroleum based product be used to clean the lights.

1.11 Testing the Lights before Installation

All Aveo Aviation lights undergo rigorous testing prior to being released from our engineering manufacturing department. This testing involves a burn-in time as well as other function testing. No light is released for sale without undergoing this extensive operational testing.

When you receive the **Maximus 64 28VDC** light, and wish to test the function of the light prior to installation on your aircraft, please note the following:

1. Please review the written information that is enclosed in the packaging. Warranty information as well as a cautionary note about power supply removal is enclosed with each package.

2. Remove the light from the package. Note that there is connector with 2 colors:

- Black – Ground
- Red – Power

3. Testing of the function of the light can be done with a regular 28VDC power supply (not a battery charger). Connect the ground wire to black pole and then connect the power wire to the red pole. The Maximus 64 28VDC light should start lighting. When installed on the aircraft, using the aircraft's power (28 VDC), the light will be at its maximum intensity.

After testing, the light can be installed on the aircraft.

IMPORTANT NOTES:

Under no circumstances should any power supply other than a 18-36VDC, or a 28 volt battery be used to test the light. Do not use: Battery chargers, battery back-up power devices, or other bench avionics testing methods to test the aviation light. The light is functional at 18-36 volts. Use of a battery charger or other power unit to test the light will void the warranty and may damage the light.

If you have any questions about the installation of the lights, please refer to our web site: www.aveoengineering.com

1.12 Notes on Installation

Spread the tightening forces evenly around the mounting hole. Stainless steel screw is recommended. Length depends upon placement location on aircraft.

1.13 Continued Airworthiness Information

Circuit/Wiring Protection

Each Maximus 64 28VDC series light features a **Negative Temperature Coefficient** (NTC) circuit that limits internal temperatures by attenuating operating current (with a corresponding reduction of brightness) when internal temperatures reach a certain threshold. This proprietary circuitry serves to protect the light itself, and associated aircraft wiring, against a thermal runaway condition.

1.14 RoHS Compliance Statement

Scope

This statement clarifies Aveo Engineering's compliance with European Union Directive 2015/863/EU on the restriction of the use of certain hazardous substances in electrical and electronic equipment ("RoHS") that took effect on June 4, 2015. The RoHS Directive restricts the sale of electronic equipment containing certain hazardous substances in the European Union including:

Cadmium(Cd): 0.01%

Mercury: 0.1%

Lead(Pb): 0.1%

Hexavalent chromium (Cr6+): 0.1%

Polybrominated biphenyls (PBB): 0.1 %;

Polybrominated diphenyl ethers (PBDE): 0.1 %

Bis(2-Ethylhexyl) phthalate (DEHP): 0.1% (added in 2015);

Benzyl butyl phthalate (BBP): 0.1% (added in 2015);

Dibutyl phthalate (DBP): 0.1% (added in 2015);

Diisobutyl phthalate (DIBP): 0.1% (added in 2015)

Compliance

Aveo Engineering certifies that all products sourced from manufacturing facilities comply with the environmental standards set forth by the Directive 2015/863/EU, recast amendment of RoHS Directive 2011/65/EU Article (4), and do not contain any of the above-mentioned, 10 hazardous substances above the specified limits. All products manufactured by Aveo Engineering are RoHS-compliant. With regards to RoHS-2 CE marking, product packaging is labeled attesting conformity if required.

References

Directive 2015/863/EU of the European Parliament and of the Council on the restriction of the use of certain hazardous substances in electrical and electronic equipment.