



INSTALLATION MANUAL

Ultra Galactica Embedded

AVE-WPS-64G-IM

© Aveo Engineering Group, s.r.o. All rights reserved. The information contained within this document must not be disclosed, copied or reproduced in whole or in part without prior written permission from Aveo Engineering Group, s.r.o.

TABLE OF CONTENTS

PART 0 DOCUMENT ADMINISTRATION	3
0.1 DOCUMENT APPROVAL	3
0.2 AMENDMENT RECORD PROCEDURE	4
0.3 AFFECTED PAGES PROCEDURE	5
PART 1 PART 1 INSTALLATION DATA	6
1.1 ULTRA GALACTICA™ (EMBEDDED).....	6
1.2 OPERATING INSTRUCTIONS	7
1.3 INSTALLATION SCHEMATIC / WIRING DIAGRAM.....	7
1.4 CONTROL & POWER INPUTS.....	7
1.5 TECHNICAL SPECIFICATION	8
1.6 TECHNICAL DRAWING.....	9
1.7 WIRING CHART	10
1.8 EQUIPMENT LIMITATION	10
1.9 TESTING THE LIGHTS BEFORE INSTALLATION	11
1.10 NOTES ON INSTALLATION	12
1.11 CARE AND CLEANING OF LIGHTS	12
1.12 CONTINUED AIRWORTHINESS INFORMATION	12
1.13 RoHS COMPLIANCE STATEMENT	14

Part 0 Document Administration

0.1 Document Approval

This document has been established in accordance with an alternative procedure to DOA approved under EASA AP429.

This installation manual is applicable for following part numbers (Modification status Mod(4) or higher):

- Ultra Galactica Embedded Red **AVE-WPSR-64G**
- Ultra Galactica Embedded Green **AVE-WPSG-64G**



Compiled by: _____ 7. January 2021

Petr Jaroš
Engineer, Aveo Engineering Group, s.r.o.



Approved by: _____ 7. January 2021

Georg Hartl
Head of DO, Aveo Engineering Group, s.r.o.

0.2 **Amendment Record Procedure**

The master copy of this document shall be kept electronically as a read only document under the control of Aveo Engineering Group, s.r.o. as Master Copy.

ALL amendments to this manual will initiate a raise of issue.

The original issue will be identified by “**01**”, and subsequent issues will be numbered sequentially from 02 to 99 in Table 01 - **Issue No.** column.

ALL issues of this document will be approved by Head of DO.

Issue No.	Details	Date of issue	Effected Pages
01	Initial Issue	15 Jun. 2015	ALL
02	Addition of FAA required statements	10 Nov. 2015	7, 9
03	Change of category for section 4 in Summary of Environment. Tests	14 Feb. 2017	7
04	New structure of document: Part 1 was set out of Part 0 Deleted text on encapsulation, deleted position function, changed input voltage range, added Mod(3) to P/N Added text to Operating instructions Added details to graphic presentation and text in chap. Installation schematic / wiring diagram, Control & power inputs Change to Technical specification Change to Technical drawings (changed dimension round off) Changed Equipment limitation Modified text on Testing the lights Deleted text in Notes on installation, Care and cleaning Changed images of lights	27 Jul. 2017	6 7 8 9, 10 11 12 13 14 16
05	Weight update Electronics data update Drawing update (not marked) ROHS addition	07 Jan. 2021	6, 8 8 9 14

Table 01: Record of Document Amendments

0.3 Affected Pages Procedure

ALL pages affected by ANY raise of issue of this document will be listed in Table 01 - **Affected Pages** Column.

The reason(s) for **EACH** raise of issue and the description of respective change will be provided in Table 01 - **Details** Column.

Changes from the previous issue are shown as follows:

- a) new text is highlighted with yellow shading: **new**
- b) deleted text is shown with yellow shading and a strike through: ~~deleted~~

Part 1 Part 1 Installation data

1.1 *Ultra Galactica*[™] (Embedded)

The **Ultra** series lights are a very popular choice for certified and general aviation aircraft of any size, due to their compact design and easy installation. With full optical testing for brightness and chromaticity, the Ultra also underwent the rigorous DO-160 testing regime and was recognized as exceeding all requirements. The **Ultra** has also become the leading wing light solution for numerous military and law enforcement/surveillance UAVs around the world and is very popular with aircraft manufacturers.

Packed with 26 ultra-high brightness LEDs that are the industry state-of-the-art in performance and output lumens, the **Ultras** still feature the same tiny footprint the popular **Aveo** e-series wing lights have become so well-known for in the aviation world.

Main features:

- 2-in-1 Navigation/Strobe
- Extremely lightweight at 96 grams
- 9-36 V DC input range
- No external power supply or strobe unit
- Light synchronization feature
- Unmatched circuit technology
- Advanced computer and Gonio photometer engineered optics

Part numbers of major components that make up the equipment complying with the standards specified in ETSO are as follows:

- Ultra Galactica (Embedded) Red PN: AVE-WPSR-64G Mod(4)
- Ultra Galactica (Embedded) Green PN: AVE-WPSG-64G Mod(4)

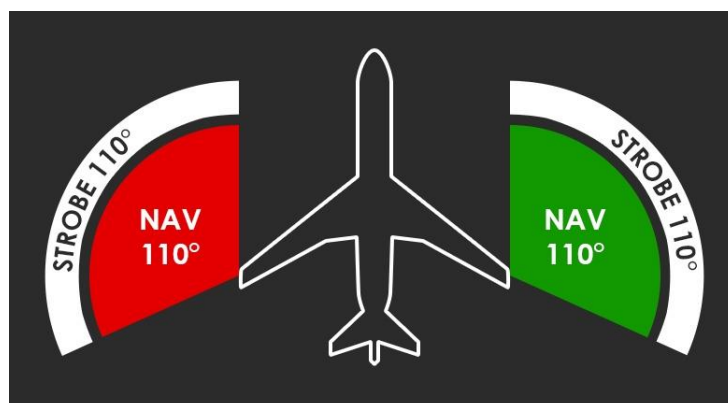

Figure 01: Features of Ultra Galactica (Embedded)

1.2 Operating Instructions

When installed on the aircraft, using the aircraft's power (14 or 28 volts), the **Ultra Galactica** light will be at its maximum intensity.

It meets the requirements of **ETSO-C30c** (Aircraft Position Light, **SAE A S S017 rev. B, SAE A S 8037 rev. A**) and **ETSO-C96a** (Anticollision Light System). The light operates within the range of voltage from 9 V to 36 V DC.

1.3 Installation Schematic / Wiring Diagram

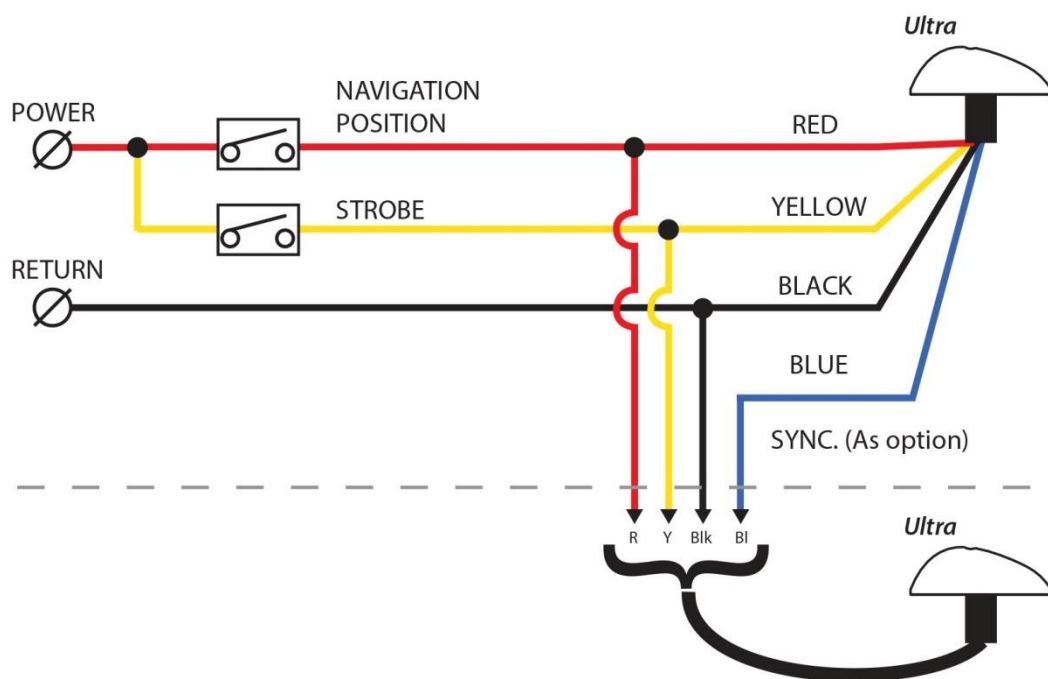

WIRES:

Teflon insulation, 500V, AWG 20, 22

Wire length from base of unit 254mm [10.00 inch] min.

1.4 Control & Power Inputs

- VCCP** - AWG 20, Positive power supply line for position (RED)
- VCCS** - AWG 20, Positive power supply line for strobe (YELLOW)
- GND** - AWG 20, Common negative power supply line (BLACK)
- SYNC** - AWG 22, Synchronization line (BLUE)

1.5 Technical Specification

Dimensions: 100 mm x 46.2 mm x 34.1 mm
3.94" x 1.819" x 1.34"

Weight: 96 g / 3.386 oz.

Operating voltage range: 9 to 36 V DC

Operating temperature: -55 °C ~ + 85 °C
-67 °F ~ +185 °F

Power:

- Position branch (red), input power:

9 V / 0.37 A:	3.33 W
14 V / 0.25 A:	3.50 W
28 V / 0.13 A:	3.64 W
36 V / 0.11 A:	3.96 W

- Strobe branch (left), input power:

9 V / 5.62 A:	50.58 W
14 V / 2.79 A:	39.06 W
28 V / 1.29 A:	36.12 W
36 V / 1.00 A:	36.00 W

- Position branch (green), input power:

9 V / 0.42 A:	3.78 W
14 V / 0.28 A:	3.92 W
28 V / 0.15 A:	4.20 W
36 V / 0.12 A:	4.32 W

- Strobe branch (right), input power:

9 V / 5.65 A:	50.85 W
14 V / 2.78 A:	38.92 W
28 V / 1.29 A:	36.12 W
36 V / 1.00 A:	36.00 W

Repetition Flash Rate of Strobe: 50 cycles per minute

Recommended size of mounting screws: M5 x 40 mm (DIN7984) or equivalent

Meets and exceeds requirements of:

- ETSO C30c, ETSO C96a
- SAE AS8017 rev. B and SAE AS8037 rev. A
- DO-160F (G)

1.6 Technical Drawing

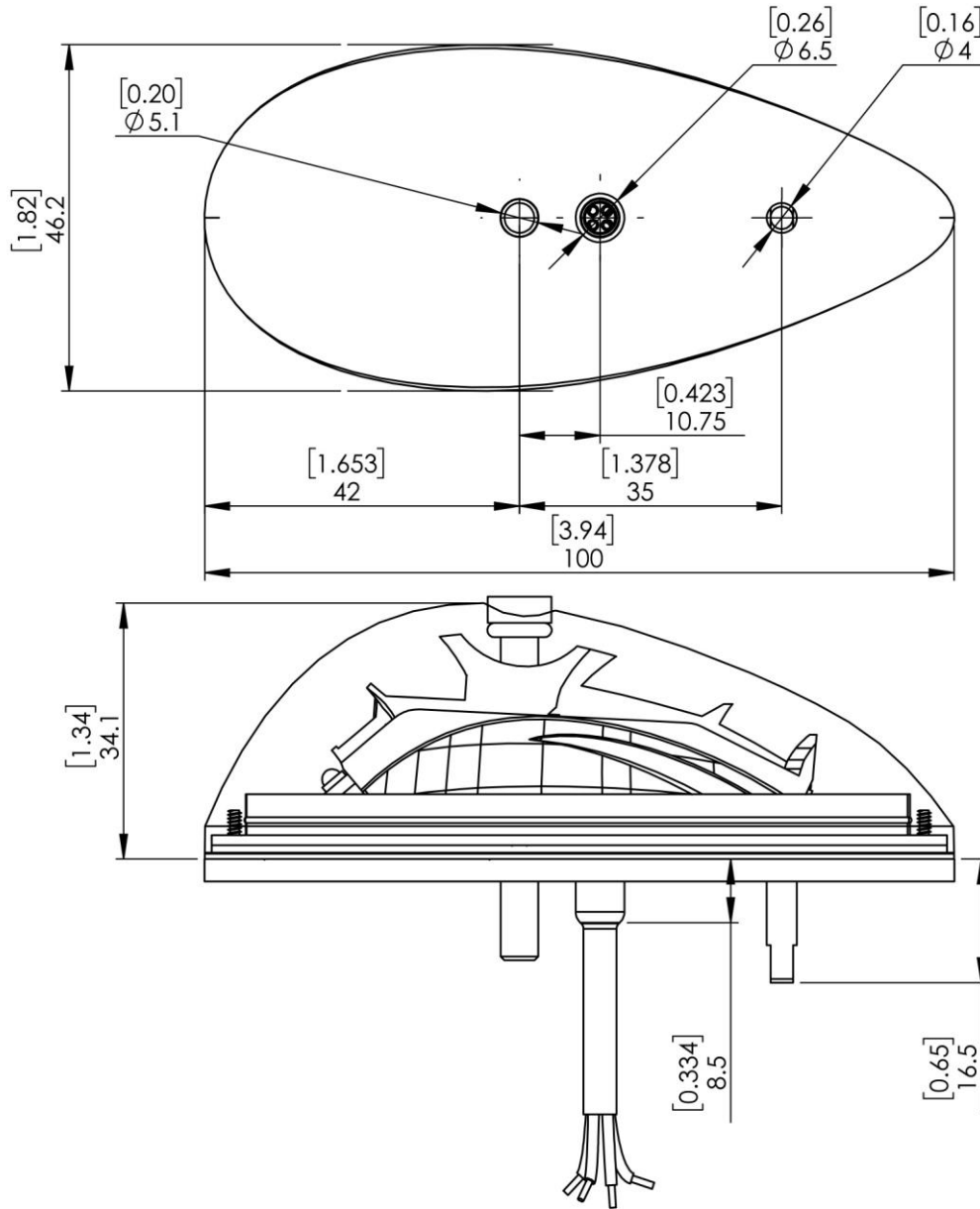

*dimensions in mm / [inches]

1.7 Wiring Chart

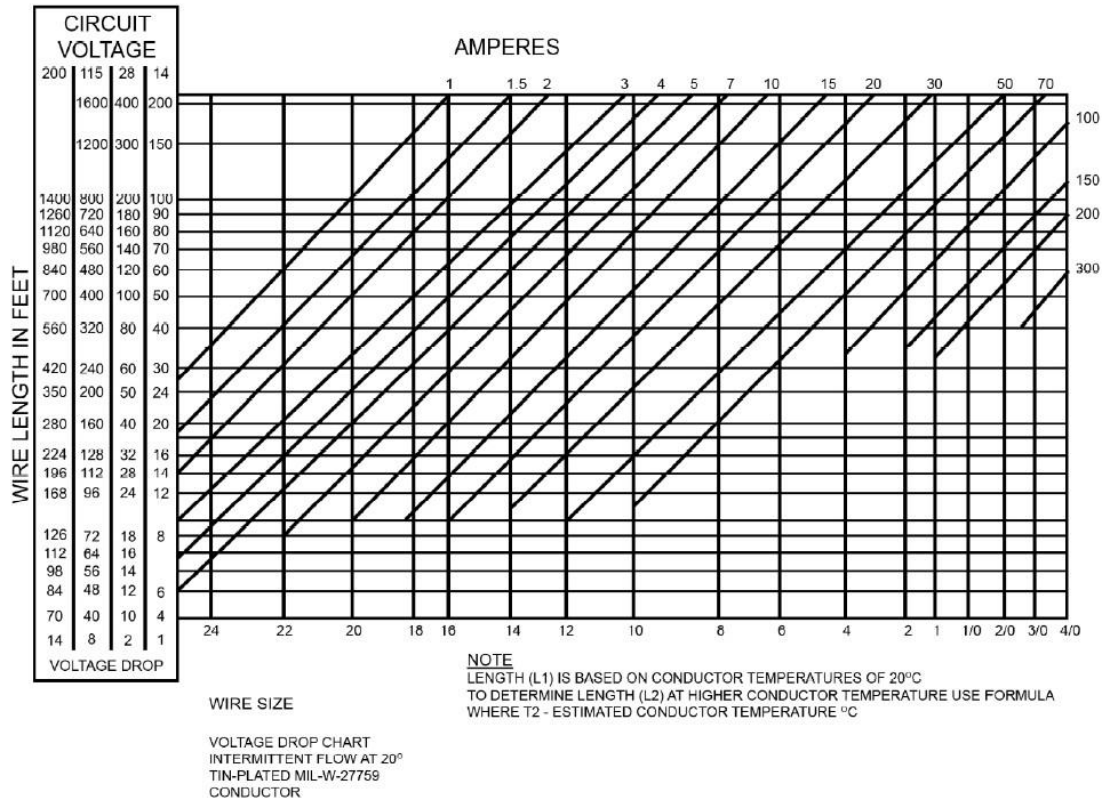

1.8 Equipment Limitation

Ultra Galactica Embedded™ should only be powered by 9-36 V DC, typically a 12V or 24V aircraft battery.

This article meets the minimum performance and quality control standards required by the technical standard orders ETSO C30c and ETSO C96a. Installation of this article requires separate approval.

Deviations

This article deviates from ETSO C30c and ETSO C96a by the usage of newer revisions of the following standards:

- SAE AS 8017 rev. B used instead of SAE AS 8017 rev. A,
- SAE AS 8037 rev. A used instead of SAE AS 8037 initial release.

1.9 *Testing the Lights before Installation*

All Aveo Aviation lights undergo rigorous testing prior to being released from our engineering manufacturing department. This testing involves a burn-in time as well as other function testing. No light is released for sale without undergoing this extensive operational testing.

When you receive the **Ultra Galactica Embedded™** light, and wish to test the function of the light prior to installation on your aircraft, please observe the following procedure:

1. Review the written information that is enclosed in the packaging. Warranty information as well as a cautionary note about power supply removal is enclosed in each package.
2. Remove the light from the package. Note that there are four (4) wires coming from each light. The wires are as follows:

Black	ground (negative lead)
Red	position/navigation light function (positive lead)
Yellow	strobe light function (positive lead)
Blue	synchro

3. Testing the function of the light can be accomplished using a regular 12V/5A DC power supply (not a battery charger).

Connect the black wire to the ground (negative) leads of a power supply, then connect the yellow or red wire to the positive (+) leads on the power supply. The light should start flashing (yellow wire = strobe light) or lighting (red wire = green/red light). Connecting the blue wires from each **Ultra Galactica Embedded** light together (and not to the ground or positive terminals on the battery) should result in flashing all lights at once. It indicates that the synchronization feature is working properly.

When installed on the aircraft and using the aircraft's power (14 or 28 volts), the light will be at its maximum intensity.

If the tests are successfully completed, the lights can be installed on the aircraft.

IMPORTANT NOTES:

1. Under no circumstances should any power supply other than a 9-36 V DC, or a 12/24V battery be used to test the light. Do not use: Battery chargers, battery back-up power devices or other bench avionics testing methods to test the aviation light. The light is functional between 9 and 36 V. Use of a battery charger or other power unit to test the light will void the warranty and may damage the light.
2. All power supplies for existing strobe lights, flasher beacons, etc. are required to be removed from the aircraft prior to the installation of the **Aveo** light.

If you have any questions regarding the installation of the lights, please refer to our web site: www.aveoengineering.com and check FAQ and other links on our aviation lights web page.

1.10 Notes on Installation

Stainless steel M5 screws are recommended to be used for installation. Screw length depends on placement of screws on wingtips.

1.11 Care and Cleaning of Lights

Aveo Engineering Aviation Lights are factory polished and delivered as ready to install on the aircraft.

Upon installation, apply one or two coats of quality automotive polish. This should protect the lights from dirt and other environmental factors. Once or twice a month, just refresh the polish and buff the lights by hand.

1.12 Continued Airworthiness Information

From the webpage <http://www.aveoengineering.com/> the customer can download the form F-AVE-001A which shall be used by operator for reporting any occurrences to the Aveo Engineering as the ETSO holder. The form contains the Aveo Engineering telephone number and the occurrence e-mail address (occurrence@aveoengineering.com).

The operator shall report immediately as the ETSO holder is obliged to report occurrences having potential to lead to an unsafe condition within 72 hours.

a. Circuit/Wiring Protection

Each **Galactica** series light features a **Negative Temperature Coefficient** (NTC) circuit that limits internal temperatures by attenuating operating current (with corresponding reduction of brightness) when internal temperatures reach a certain threshold. This proprietary circuitry is intended for protecting the light itself, and associated aircraft wiring, from a thermal runaway condition. The operation of strobes without airflow is recommended to be limited in order to avoid heat buildup. This NTC circuitry feature enables the life of LEDs and electronic components to be tripled and thereby provide an even great margin of safety for continued airworthiness due to the dramatic enhancement of electronics reliability.

b. Periodic Inspection Procedure

The **Ultra Galactica Embedded** lights should always be checked for proper operation during preflight. This procedural information is already provided in all general aviation aircraft flight manuals.

The lights should be visually examined for general condition, proper operation, and correct installation at each inspection to be carried out annually and/or after 100 hours of operation. Any debris or atmospheric deposits accumulated on the surface of the lights should be removed using a UV Wax such as Farecia Profile UV Wax to ensure ongoing optical clarity. In addition, refer to section 1.11 of installation manual for detailed cleaning instructions.

The following procedure shall be performed, firstly, in the steady mode and secondly, in the strobe mode:

1. Put on polarized sunglasses or welder goggles to prevent eye damage when looking into the lights.
2. Turn the lights on.
3. Examine the individual LEDs in accordance with the figures 2-4 below. *If any of the LEDs fail, the light shall be removed and sent to Aveo Engineering for replacement under the Warranty Program.*

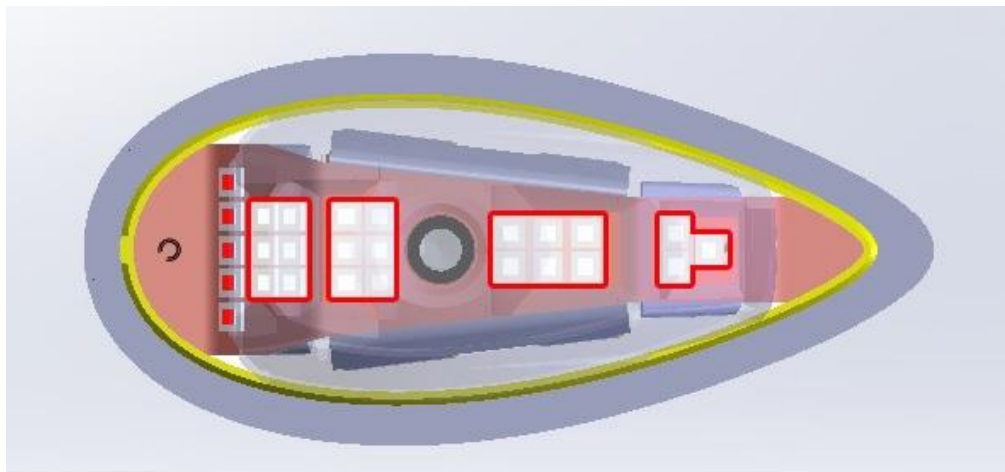

Figure 2: Strobe LEDs

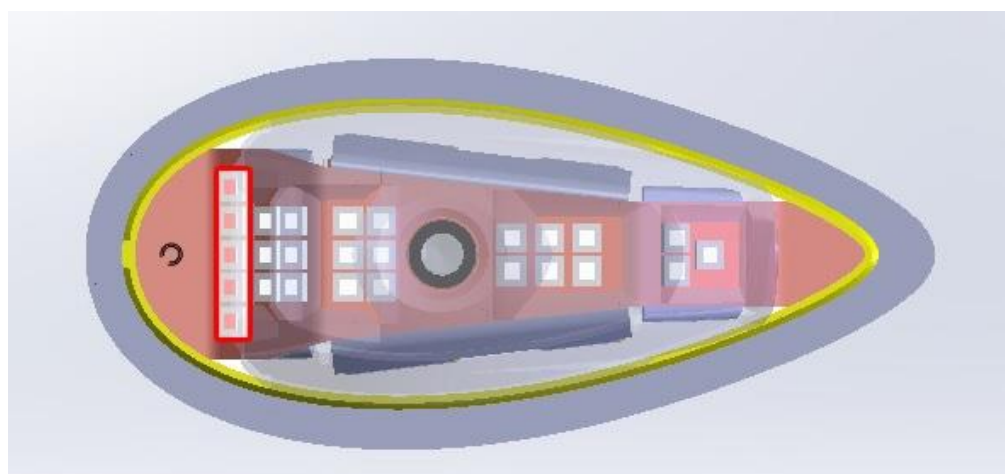

Figure 3: Position LEDs (colored)

1.13 RoHS Compliance Statement

Scope

This statement clarifies Aveo Engineering's compliance with European Union Directive 2015/863/EU on the restriction of the use of certain hazardous substances in electrical and electronic equipment ("RoHS") that took effect on June 4, 2015. The RoHS Directive restricts the sale of electronic equipment containing certain hazardous substances in the European Union including:

Cadmium(Cd): 0.01%

Mercury: 0.1%

Lead(Pb): 0.1%

Hexavalent chromium (Cr6+): 0.1%

Polybrominated biphenyls (PBB): 0.1 %;

Polybrominated diphenyl ethers (PBDE): 0.1 %

Bis(2-Ethylhexyl) phthalate (DEHP): 0.1% (added in 2015);

Benzyl butyl phthalate (BBP): 0.1% (added in 2015);

Dibutyl phthalate (DBP): 0.1% (added in 2015);

Diisobutyl phthalate (DIBP): 0.1% (added in 2015)

Compliance

Aveo Engineering certifies that all products sourced from manufacturing facilities comply with the environmental standards set forth by the Directive 2015/863/EU, recast amendment of RoHS Directive 2011/65/EU Article (4), and do not contain any of the above-mentioned, 10 hazardous substances above the specified limits. All products manufactured by Aveo Engineering are RoHS-compliant. With regards to RoHS-2 CE marking, product packaging is labeled attesting conformity if required.

References

Directive 2015/863/EU of the European Parliament and of the Council on the restriction of the use of certain hazardous substances in electrical and electronic equipment.