

AveoAir™ Maxi

Air Vents

Colors:

Silver anodizing – AVE-BMSLV-001

Black anodizing – AVE-BMBLK-001

Material:

Weight:

Anodized Aluminium
approx 99 g / 3.492 oz



Drawing

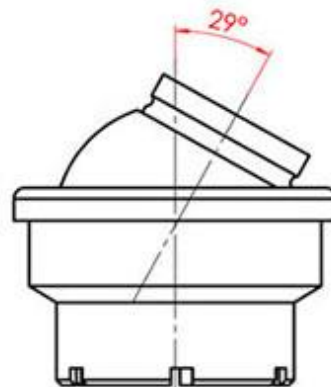
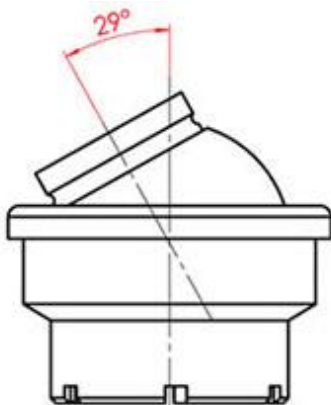
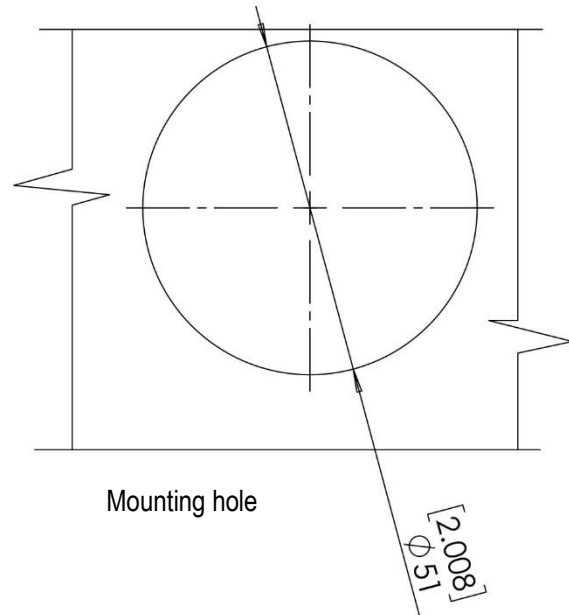
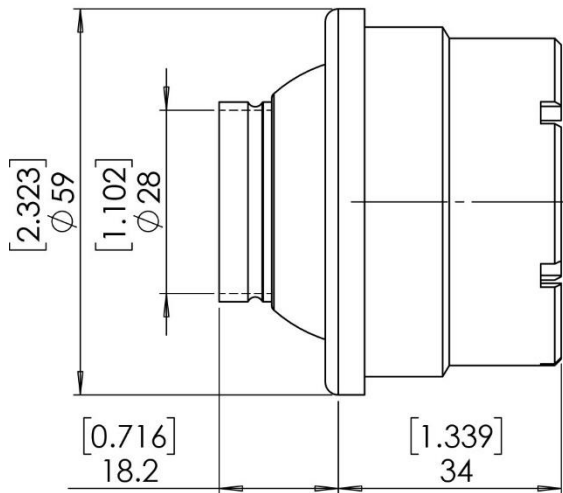

PN: AVE-BMBP-150 - Ball Vent Rear Part 1 ½"

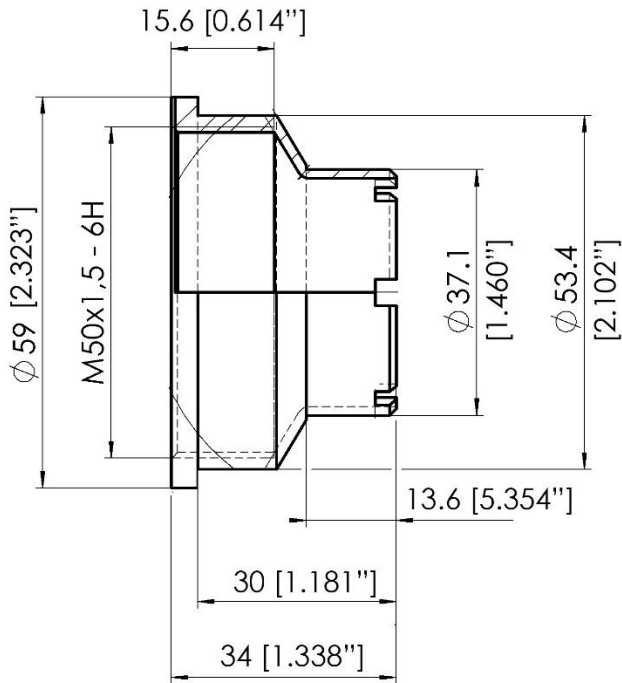

PN: AVE-BMBP-170 Ball Vent Rear Part 1 ¾"

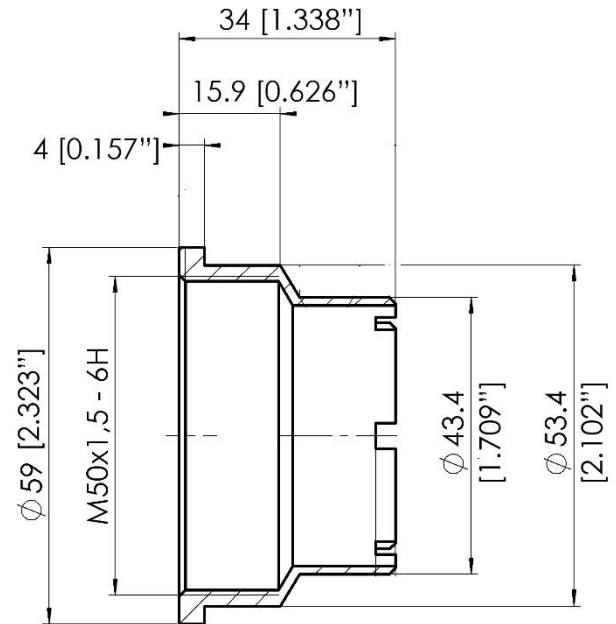

PN: AVE-BMBP-200 - Ball Vent Rear Part 2"

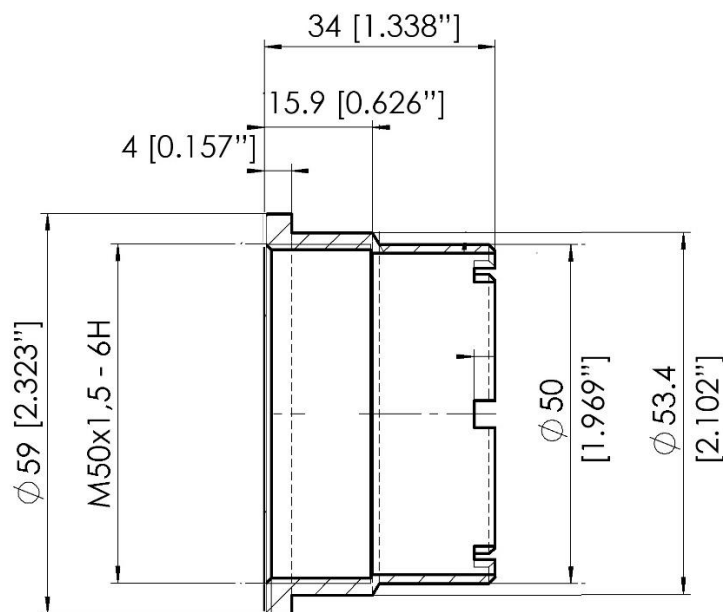

Dimensions in mm [inches]

Velocity [ft/min]	1000	1500	2000	2500	3000	3500	4000
CFM	14.07	21.11	28.15	35.18	42.22	49.25	56.29
Static Pressure [in H ₂ O]	0.13	0.29	0.51	0.78	1.13	1.50	2.03
Projection [ft] at 100 [ft/min]	5.90	8.88	12.82	18.03	22.56	11.87	14.20
Projection [ft] at 200 [ft/min]	3.05	4.27	5.54	6.73	8.11	9.85	12.60
Projection [ft] at 400 [ft/min]	1.68	2.24	2.88	3.44	4.06	4.70	5.38

Airflow CFM:

Standard air density and isothermal conditions

Static Pressure:

Inches of water gauge required

Projection:

Projection distance (THROW) in feet from the Nozzle discharge at which the maximum velocity has been reduced to specified terminal velocity (Vt).