

SuperNova DayLite WHITE / RED or WHITE / IR

Anti-collision LED light



Specification

Dimensions (mm):	199.5 mm x 58.5 mm x 30 mm
Dimensions (inches):	7.854" x 2.3" x 1.183"
Weight:	250 g / 0.55 lbs
Operating Voltage Range:	18 – 36 V DC
Input Current – White Strobe (@28V):	3.6 A
Input Current – Red Strobe (@28V):	1.2 A
Input Current – IR Strobe (@28V):	N/A
Output Power – White Strobe (@28V):	86.4 W
Output Power – Red Strobe (@28V):	30.3 W
Output Power – IR Strobe (@28V):	25.6 W
Repetition Rate of Strobe:	50 cycles per minute
Ambient Temperature:	from -50°C to +85°C from -67°F to +185°F
Overheat Protection	+85°C
Recommended size of mounting screw:	M4 (SHCS #8-32)
Reverse Polarity Protection	YES
Transient Voltage	60V, both polarities
Under-Voltage Protection (lockout)	YES (18V)
Over-Voltage protected (lockout)	YES (36V)
Waterproof, Dust-proof, Shock-proof, Vibration-proof	YES

Drawing

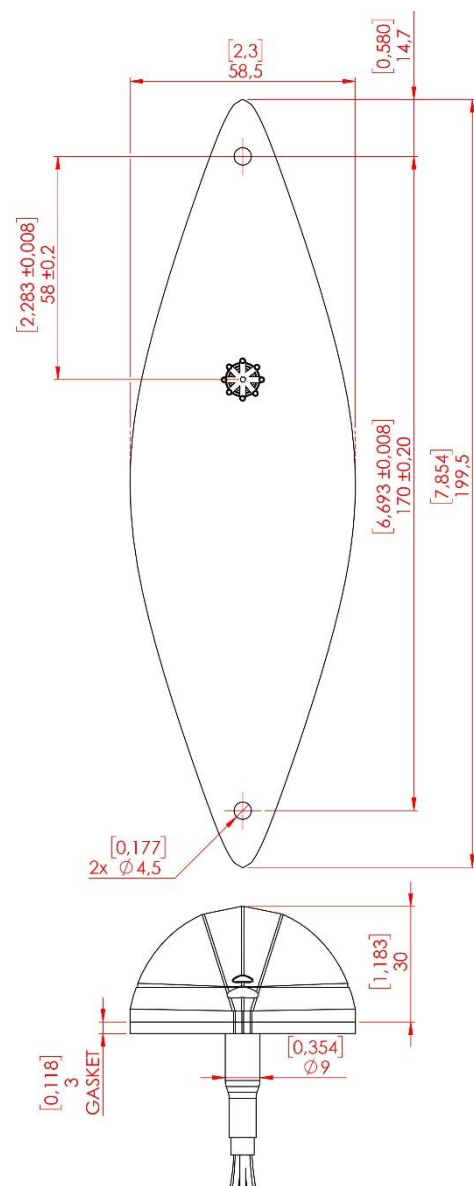

Dimensions in mm / inches

**NOT APPROVED FOR INSTALLATION ON CERTIFIED AIRCRAFT
THIS IS NOT A TSO/ETSO CERTIFIED LIGHT**