

Hercules JP™ 28V

PAR36 Landing or Taxi Light



Taxi – natural	- AVE-HJPDOTW-DS2
Landing – natural	- AVE-HJPDOLW-DS2
Taxi – black	- AVE-HJPDOTW-DB2
Landing – black	- AVE-HJPDOLW-DB2
Taxi – green	- AVE-HJPDOTW-DG2
Landing – green	- AVE-HJPDOLW-DG2
Taxi – red	- AVE-HJPDOTW-DR2
Landing – red	- AVE-HJPDOLW-DR2
Taxi – blue	- AVE-HJPDOTW-DU2
Landing – blue	- AVE-HJPDOLW-DU2

Specification

Dimensions (mm):	111.5 mm x 44 mm
Dimensions (inches):	4.39" x 1.73"
Weight:	292 g / 10.3 oz
Operating Voltage Range:	18 – 36 V DC
Input Current:	2.15 A @ 28 V
Output Power:	54 W
Landing Lens Angle:	8° Landing
Taxi Lens:	9° x 20° Taxi
Intensity (Landing):	100,000 cd
Intensity (Taxi):	51,000 cd
Ambient Temperature:	from -55°C to +85°C from -67°F to +185°F
Overheat Protection:	Yes (temperature dependent decrement of intensity, see note below)
Transient Voltage:	80 V max
Over-Voltage Lockout:	36 V DC
Reverse Polarity Protection:	Yes
Useful Life:	Not less than 30,000 aircraft flight hours
Waterproof, Dust-proof, Vibration-proof:	Yes

Drawing

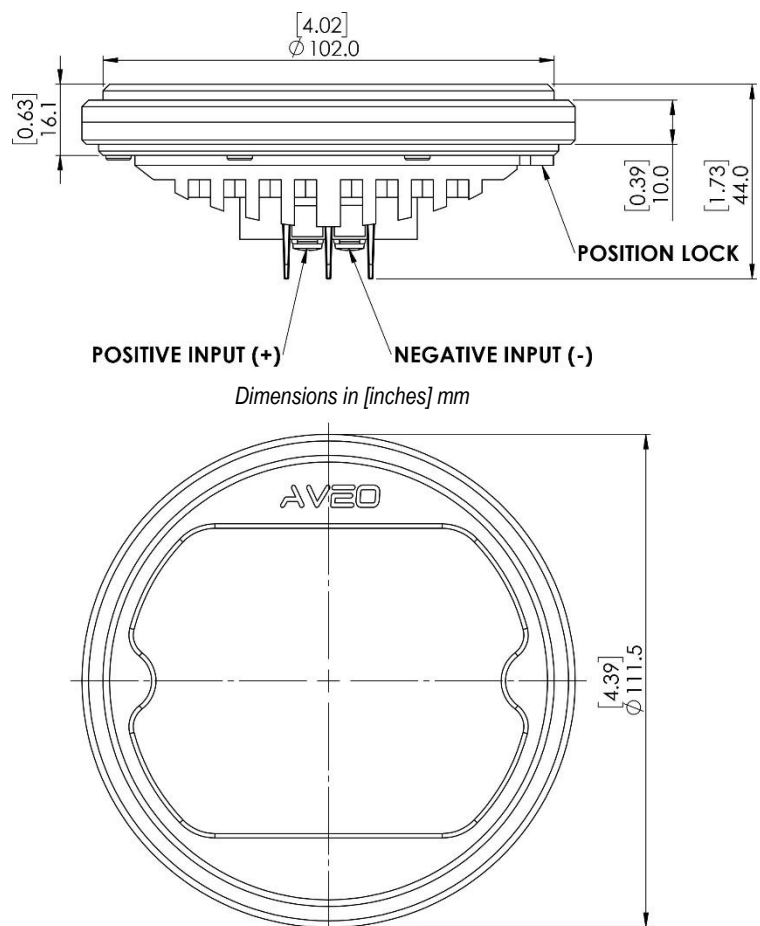

NOTE: If the light heats up to the temperature of 85°C (+/-10%), the output drops linearly by up to 10 % from the nominal value until it cools down to 60°C (+/- 10%). As soon as the temperature of 60°C (+/- 10%) is achieved, the light operates at full power again.

In case, when in the process of cooling down the power supply is interrupted and the temperature is within the range of 60°C (+/- 10%) - 85°C (+/-10%), then after turning on, the light starts to operate at full power until its temperature rises to 85°C (+/-10%).

Hercules JP™ 28V

PAR36 Landing or Taxi Light



Color Options



Black



Natural



Blue



Green



Red