



Specification sheet

NUBION

Taxi or Landing LED Light Replacement for Legacy Light

1. PRODUCT INFO

Taxi or Landing LED light replacement for legacy light.

2. WIRING DIAGRAM

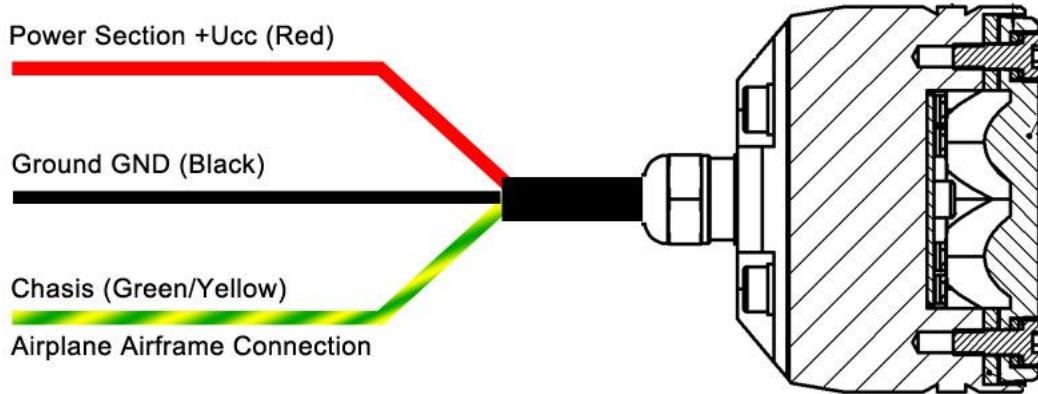

3. TECHNICAL SPECIFICATION

Electronic specification - Ambient temperature (25°C):

Operating voltage:	18-36V DC
Primary input voltage:	28V DC
Over-voltage protection:	80V (1s)
Input current at 28V:	0.75A (+/- 5%)
Input current at 18V:	1.2A (+/- 5%)
Reverse polarity protection:	Yes
Over-Voltage shut down:	38.5V DC
Under-Voltage protection:	Yes
Operating temperature:	from -55°C to +85°C / from -67°F to +185°F
Over-Temperature protection:	Yes
Output power:	18W
Weight:	7.76oz (220g)
Taxi lens:	40° x 20°
Landing lens:	12°

4. TECHNICAL DRAWING

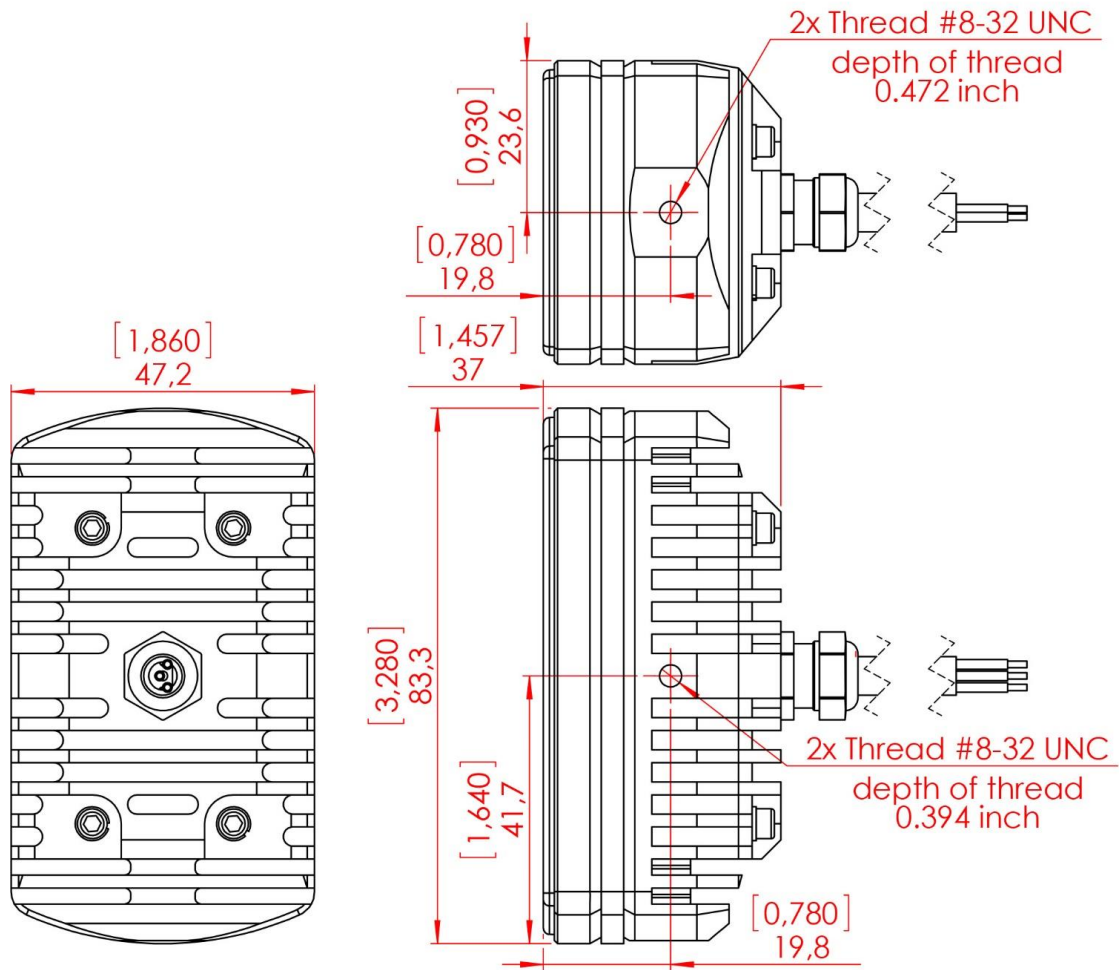

dimensions in mm [inches]

5. WIRING CHART

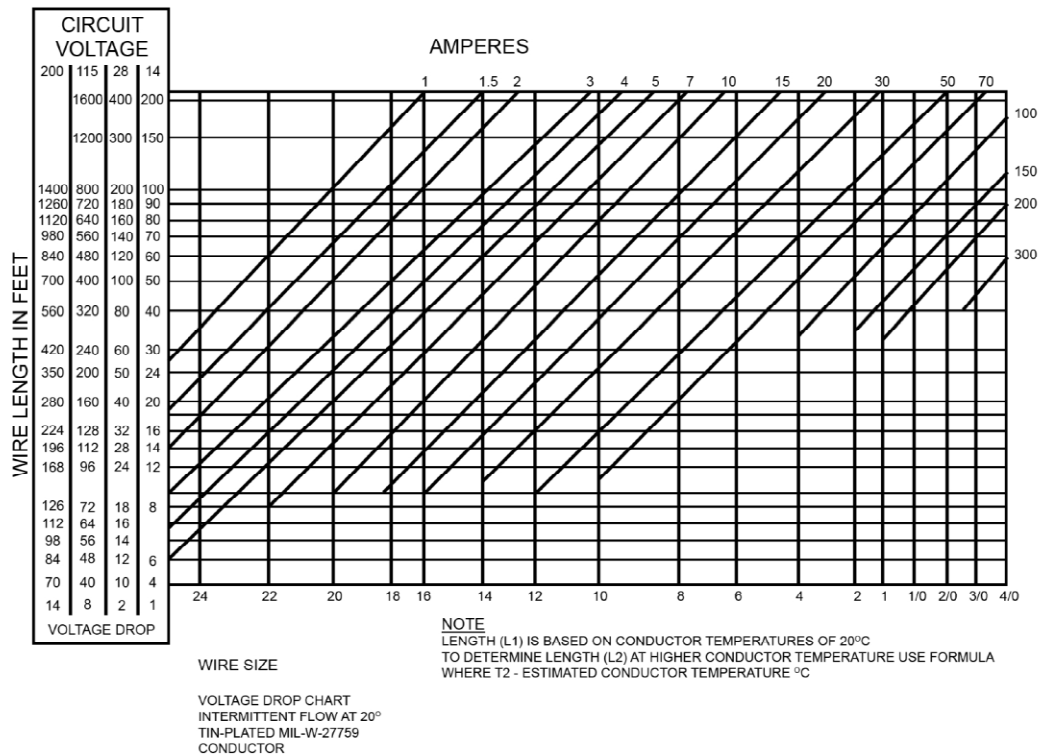

6. TESTING THE FUNCTION OF THE AVEO LIGHTS BEFORE INSTALLATION

All Aveo Aviation lights undergo rigorous testing prior to being released from our engineering manufacturing department. This testing involves a burn-in time as well as other function testing. No light is released for sale without undergoing this extensive operational testing. When you receive the Nubion light, and wish to test the function of the light prior to installation on your aircraft, please note the following:

1. Please review the written information that is enclosed in the packaging. Warranty information as well as a cautionary note about power supply removal is enclosed with each package.
2. Remove the light from the package. Note that there are 3 cables:
 - positive lead – red
 - negative lead – black
 - chasis – green/yellow
3. Testing of the function of the light can be done with a regular 24V/5A dc power supply (not a battery chargers). Connect black wire to the ground (negative) leads of a power supply, then connect red wire to the positive (+) leads on the power supply. The taxi light should start lighting. When installed on the aircraft, using the aircraft's power (28 volts), the light will be at its maximum intensity.

After testing, the light can be installed on the aircraft.

IMPORTANT NOTES:

1. Under no circumstances should any power supply other than a 18-36 Vdc, or a 24 volt battery be used to test the light. Do not use: Battery chargers, battery back-up power devices, or other bench avionics testing methods to test the aviation light. The light is functional between 18 and 36 volts. Use of a battery charger or other power unit to test the light will void the warranty and may damage the light.
2. All power supplies for existing strobe lights, flasher beacons, etc. are required to be removed from the aircraft prior to the installation of the Aveo light.

If you have any questions about the installation of the lights, please refer to our web site: www.aveoengineering.com

7. CARE AND CLEANING OF YOUR AVEO ENGINEERING AVIATION LIGHTS

When you receive your Aveo Engineering Aviation Lights, they will have been factory polished and ready to install on the aircraft..

If the lights require a deeper cleaning, they should be polished with a quality lamb's wool sheet and can also be used for deeper polishing. Under no circumstances should any petroleum based product be used to clean the lights.