

Ultra Embedded DayLite™

Navigation / Strobe LED light

Red LEDs P/N: AVE-WPSR-64T Mod(4)

Green LEDs P/N: AVE-WPSG-64T Mod(4)



Specification

Dimensions (mm):	100 mm x 46.2 mm x 34.1 mm
Dimensions (inches):	3.94" x 1.819" x 1.34"
Weight:	113 g / 3.985 oz
Operating Voltage Range:	9 – 36 V DC
Input Power	9 V / 0.42 A : 3.78 W
P/N: AVE-WPSG-64T Mod(4)	14 V / 0.28 A : 3.92 W
Nav Green:	28 V / 0.15 A : 4.20 W
	36 V / 0.12 A : 4.32 W
Input Power	9 V / 5.65 A : 50.85 W
P/N: AVE-WPSG-64T Mod(4)	14 V / 2.78 A : 38.92 W
Strobe:	28 V / 1.29 A : 36.12 W
	36 V / 1.00 A : 36.00 W
Input Power	9 V / 0.37 A : 3.33 W
P/N: AVE-WPSR-64T Mod(4)	14 V / 0.25 A : 3.50 W
Nav Red:	28 V / 0.13 A : 3.64 W
	36 V / 0.11 A : 3.96 W
Input Power	9 V / 5.62 A : 50.58 W
P/N: AVE-WPSR-64T Mod(4)	14 V / 2.79 A : 39.06 W
Strobe:	28 V / 1.29 A : 36.12 W
	36 V / 1.00 A : 36.00 W
Repetition Rate of Strobe:	50 cycles per minute
Ambient Temperature:	from -55°C to +85°C from -67°F to +185°F
Overheat Protection:	Yes (+85°C)
Recommended size of mounting screw:	M5x45 mm (DIN7984) or equivalent
Torque requirement for screw M5x45mm:	1.2Nm
Reverse Polarity Protection:	Yes
Maximum Transient Voltage:	80 V at 2 sec max, both polarities
Under-Voltage Protection:	Yes
Over-Voltage Protection:	Yes
Waterproof, Dust-proof, Vibration-proof:	Yes

Drawing

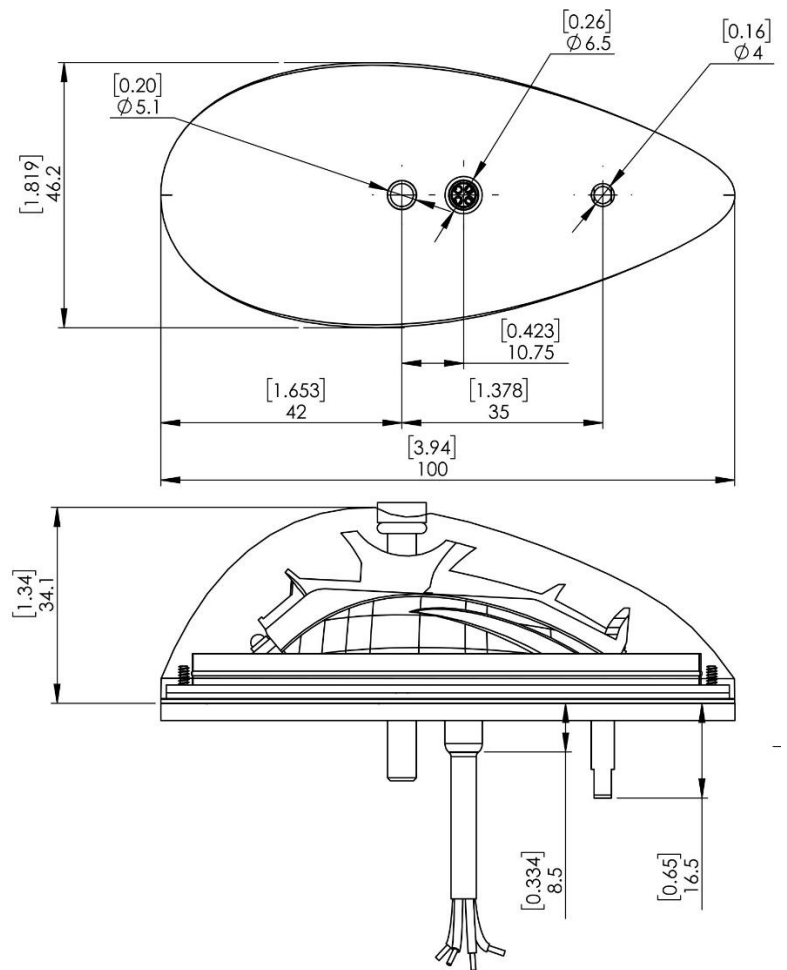

Dimensions in mm / inches

**NOT APPROVED FOR INSTALLATION ON CERTIFIED AIRCRAFT
THIS IS NOT A TSO/ETSO CERTIFIED LIGHT**

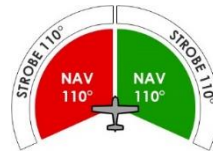

Ultra Embedded DayLite™

Navigation / Strobe LED light

Red LEDs P/N: AVE-WPSR-64T Mod(4)

Green LEDs P/N: AVE-WPSG-64T Mod(4)

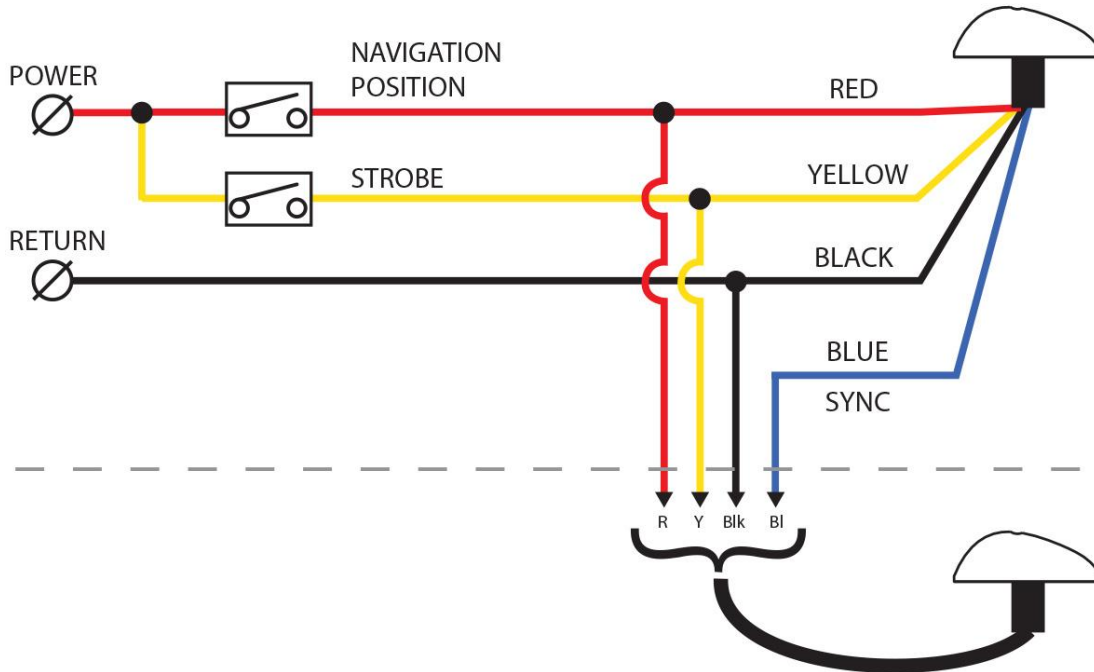

Teflon insulation, 500V

Wire length from base of unit 10.00 inch min.

VCCP - AWG 20, Positive power supply line for position (RED)

VCCS - AWG 20, Positive power supply line for strobe (YELLOW)

GND - AWG 20, Common negative power supply line (BLACK)

SYNC - AWG 22, Synchronization line (BLUE)